

FERLUX[®]
CHIMENEAS Y BIOMASA

Calidez de Vida

**PELLET
LEÑA**



ecologic

CATÁLOGO GENERAL

FABRICADO EN ESPAÑA · MADE IN SPAIN



Conforlux

- ES** Sistema automático de control de la combustión. En función de la salida de humos instalada, la altitud sobre el nivel del mar y el tipo de pellet utilizado, se regula automáticamente la cantidad de aire necesario para alcanzar siempre la combustión perfecta, garantizando bajas emisiones a la atmósfera y un consumo menor de combustible.
- EN** CONFORLUX Automatic combustion control system. Depending on the smoke outlet installed, the altitude above sea level, and the type of pellets used, the amount of air required to achieve perfect combustion is automatically regulated, guaranteeing low emissions into the atmosphere and lower fuel consumption.
- PT** CONFORLUX Sistema automático de controlo da combustão. Em função da saída de fumos instalada, da altitude acima do nível do mar e do tipo de pellets utilizados, regula-se automaticamente a quantidade de ar necessário para se alcançar sempre a combustão perfeita, garantindo baixas emissões para a atmosfera e um consumo menor de combustível.
- IT** CONFORLUX. Sistema automatico di controllo della combustione. A seconda della canna fumaria installata, dell'altezza sul livello del mare e del tipo di pellet utilizzato, regola automaticamente la quantità di aria necessaria per conseguire sempre una perfetta combustione, garantendo basse emissioni in atmosfera e minor consumo di combustibile.
- FR** CONFORLUX Système automatique de contrôle de la combustion. Selon la sortie de fumées installée, l'altitude du niveau de la mer et le type de granulés de bois utilisé, la quantité d'air nécessaire est réglée automatiquement pour atteindre toujours la combustion parfaite, en garantissant de basses émissions dans l'atmosphère et une consommation plus faible de carburant.



Potencia Automática de Combustión

- ES** La estufa, de manera automática, selecciona la potencia de combustión más adecuada considerando la temperatura ambiente de la habitación y la temperatura deseada. Mayor confort y menor consumo de combustible.
- EN** AUTOMATIC COMBUSTION LEVEL The heater automatically selects the most suitable combustion level based on the room temperature and desired temperature. Greater comfort and lower fuel consumption.
- PT** POTÊNCIA AUTOMÁTICA DE COMBUSTÃO. O fogão seleciona de forma automática a potência de combustão mais adequada, considerando a temperatura ambiente do compartimento e a temperatura desejada. Maior conforto e menor consumo de combustível.
- IT** POTENZA AUTOMÁTICA DELLA COMBUSTIONE. La stufa in maniera automatica seleziona la potenza di combustione più adatta considerando la temperatura ambiente e la temperatura desiderata. Maggior confort e minor consumo di combustibile.
- FR** PUISSANCE AUTOMATIQUE DE COMBUSTION Le poêle sélectionne, de façon automatique, la puissance de combustion plus convenable en tenant compte de la température ambiante de la pièce et de la température souhaitée. Plus de confort et une consommation de carburant réduite.



Air Silence

- ES** Sistema que permite al usuario regular la cantidad de aire caliente en la salida de la estufa, modificando de este modo el nivel de ruido del aparato según la ubicación elegida.
- EN** AIR SILENCE System that allows the user to regulate the amount of hot air in the heater outlet, thus modifying the noise level of the appliance according to the chosen location.
- PT** AIR SILENCE. Sistema que permite que o utilizador regule a quantidade de ar quente na saída do fogão, modificando deste modo o nível de ruído do aparelho de acordo com a localização escolhida.
- IT** AIR-SILENCE. Sistema che permette all'utente di regolare la quantità di aria calda in uscita dalla stufa, e modificare il livello di rumorosità dell'apparato a seconda dell'ubicazione scelta.
- FR** AIR SILENCE Système qui permet à l'utilisateur de régler la quantité d'air chaud à la sortie du poêle, modifiant de cette façon le niveau de bruit de l'appareil selon l'emplacement choisi.

Canalización

- ES** Sistema que permite llevar aire caliente a través de conductos a otras estancias mediante turbinas muy silenciosas. Controladas electrónicamente con una sonda ambiente que nos permite elegir la temperatura deseada en las habitaciones que queremos calefactar. Esto garantiza un mayor confort y un menor consumo de combustible.
- EN** CANALIZATION. System that allows to bring hot air through pipeline to other rooms by very quiet turbines. Electronically controlled with an ambient probe that allows us to choose the desired temperature in the rooms we want to heat. This ensures greater comfort and lower fuel consumption.
- PT** CANALIZAÇÃO. Sistema que permite distribuir ar quente através das condutas para outros espaços, através de turbinas muito silenciosas. Controlado eletronicamente através de uma sonda ambiente, o que permite escolher a temperatura desejada nos espaços que queremos aquecer. Isso garante maior conforto e menor consumo de combustível.
- IT** CANALIZZAZIONE. Sistema con motori a turbina molto silenziosi che tramite condotti permette di portare aria calda in altre stanze, Una sonda ambiente controllata elettronicamente ci consente di scegliere la temperatura desiderata nelle zone che vogliamo scaldare. Garanzia di maggior confort e minor consumo di combustibile.
- FR** CANALISATION. Système permettant à l'air chaud d'être acheminé par des conduits vers d'autres pièces à travers des turbines très silencieuses. Contrôlé électroniquement avec une sonde ambiante qui nous permet de choisir la température souhaitée dans les pièces à chauffer. Cela garantit un plus grand confort et une moindre consommation de carburant.



Fire-Stop

- ES** Sistema automático de apagado que se activa si la temperatura ambiente supera en tres grados la temperatura deseada por el usuario. Automáticamente volverá a encender cuando descienda un grado de la temperatura de consigna. Esto garantiza un mayor confort y un menor consumo de combustible.
- EN** FIRE STOP. Automatic shutdown system that is activated if the ambient temperature exceeds the user's desired temperature by three degrees. It will automatically turn back on when the room temperature falls one degree below the desired room temperature. This ensures optimum comfort and lower fuel consumption.
- PT** FIRE-STOP Sistema automático de desligar que se activa se a temperatura ambiente aumenta três graus acima da temperatura desejada pelo o utilizador. Automaticamente voltará a acender-se quando existe descida de um grau da temperatura desejada. Isto garante um maior conforto e um menor consumo de combustível.
- IT** FIRE-STOP. Sistema automatico di spegnimento, quando la temperatura ambiente supera di tre gradi la temperatura selezionata la stufa va in spegnimento e si riaccende quando la temperatura scende un grado sotto a quella desiderata. Garanzia di maggior confort e minor consumo di combustibile.
- FR** FIRE STOP. Système d'arrêt automatique qui démarre si la température ambiante est supérieure à trois degrés par rapport à la température souhaitée par l'utilisateur. Il démarrera de nouveau automatiquement lors du refroidissement d'un degré par rapport à la température de la consigne. Cela garantit un meilleur confort et une consommation plus faible de carburant.



Anti-Deflagración

- ES** La estufa está dotada de un doble sistema de seguridad, el primero electrónico y el segundo mecánico. Esto garantiza una total seguridad del aparato.
- EN** ANTI-DEFLAGRATION The heater is fitted with a double safety system, the first electronic and the second mechanical. This guarantees the device's absolute safety.
- PT** ANTIDEFLAGRAÇÃO. O fogão está dotado de um duplo sistema de segurança: o primeiro eletrônico e o segundo mecânico. Isto garante a segurança total do aparelho.
- IT** ANTI-DEFRAGRAZIONE. La estufa è dotata di doppio sistema di sicurezza il primo elettronico e il secondo meccanico che garantiscono la totale sicurezza dell'apparato.
- FR** ANTI-DÉFLAGRATION Le poêle est doté d'un double système de sécurité, le premier électronique et le deuxième mécanique. Cela garantit une sécurité totale de l'appareil.



Cristal Limpio

- ES** En la parte interna del cristal, una cortina de aire evita que los humos de la combustión entren en contacto con el cristal, garantizando por un largo período de tiempo la visión de la llama y una mejor combustión. También contribuimos a reducir las emisiones y el consumo de combustible.
- EN** CLEAN GLASS On the inside of the glass, an air curtain prevents combustion fumes from coming into contact with the glass, ensuring that the flame can be viewed for a longer time and improved combustion. This also contributes to reducing emissions and fuel consumption.
- PT** VIDRO LIMPO Na parte interna do vidro, uma cortina de ar evita que os fumos da combustão entrem em contacto com o vidro, garantindo a visão das chamas e uma melhor combustão por um longo período de tempo. Também contribuimos para a redução das emissões e do consumo de combustível.
- IT** VETRO PULITO: Una barriera di aria iniettata nella parte interna del vetro evita ai fumi della combustione di entrare in contatto con il cristallo, garantendo una prolungata visione della fiamma e una migliore combustione, dovuta all'apporto di aria preriscaldata nella camera di combustione, base emissioni e minor consumo di combustibile.
- FR** VETRO PROPRE Sur la partie interne du verre, un rideau d'air empêche que les fumées de la combustion prennent contact avec la vitre, en garantissant sur une longue période de temps la vision de la flamme et une meilleure combustion. On contribue aussi à réduire les émissions et la consommation de carburant.



Quemador de Hierro Fundido

- ES** Los quemadores de hierro fundido tienen la gran ventaja de soportar perfectamente las altas temperaturas sin sufrir dilataciones ni daños. Garantizando una vida útil más duradera.
- EN** CAST IRON BURNER. Cast iron burners have the great advantage of perfectly withstanding high temperatures without suffering dilation or damage. Ensuring a longer lifespan.
- PT** QUEIMADOR DE FERRO FUNDIDO. Os queimadores de ferro fundido têm a grande vantagem de suportar perfeitamente as altas temperaturas sem sofrer dilatações nem danos. Garantindo uma vida útil mais duradoura.
- IT** BRUCIATORE IN GHISA. I bruciatori in ghisa hanno la caratteristica di resistere alle alte temperature senza soffrire il problema delle dilatazioni e usure. Garantiscono una vita utile molto più larga.
- FR** BRÛLEUR EN FONTE. Les brûleurs en fonte ont le grand avantage de résister parfaitement aux températures élevées sans souffrir de dilatation ou de dommages. Garantissant une durée de vie plus longue.



Vermiculita

- ES** Todas nuestras estufas de aire tienen la cámara de combustión completamente recubierta de vermiculita (material resistente a las altas temperaturas y al contacto prolongado de la llama). Permite una mejor visión de la llama y una combustión completa disminuyendo las emisiones a la atmósfera gracias a las altas temperaturas que alcanza la cámara de combustión.
- EN** VERMICULITE The combustion chamber in all of our air heaters is fully coated with vermiculite (a material resistant to high temperatures and prolonged contact with the flame). This allows a better view of the flame and more complete combustion, reducing emissions to the atmosphere thanks to the high temperatures reached in the combustion chamber.
- PT** VERMICULITE. Todos os nossos fogões de ar têm a câmara de combustão totalmente revestida de vermiculite (material resistente a altas temperaturas e ao contacto prolongado das chamas). Permite uma melhor visão das chamas e uma combustão completa, diminuindo as emissões para a atmosfera, graças às altas temperaturas que a câmara de combustão alcança.
- IT** VERMICULITE. Tutte le nostre stufe ad aria hanno la camera di combustione interamente ricoperta di vermiculite materiale resistente alle alte temperature e al contatto prolungato con il fuoco. Miglior visione della fiamma e una combustione completa diminuendo le emissioni in atmosfera, grazie alle alte temperature che raggiunge la camera di combustione.
- FR** VERMICULITE Tous nos poêles à air ont la chambre de combustion entièrement recouverte de vermiculite (matériau résistant aux températures élevées et au contact prolongé avec la flamme). Elle permet une meilleure vision de la flamme et une combustion complète en réduisant les émissions dans l'atmosphère grâce aux températures élevées que la chambre de combustion atteint.



Limpieza paso de humos manual

- ES** Sistema que permite mantener limpias las zonas donde se produce el intercambio de calor de los residuos de la combustión, aumentando el rendimiento. Esto garantiza un mayor confort y un menor consumo de combustible.
- EN** MANUAL CLEANING PASSAGE SMOKE. System that allows to keep clean the zones which produces the exchange of heat of the combustion residues, increasing the efficiency. This ensures greater comfort and lower fuel consumption.
- PT** ETAPA LIMPEZA MANUAL DE FUMOS. Sistema que permite manter manualmente a limpeza das áreas onde ocorre a troca de calor dos resíduos de combustão, aumentando o rendimento. Isso garante maior conforto e menor consumo de combustível.
- IT** PULIZIA MANUALE PASSAGGI FUMI. Sistema che permette di tenere pulita dei residui della combustione la zona dello scambiatore il calore, aumentando il rendimento. Garanzia di maggior confort e minor consumo di combustibile.
- FR** NETTOYAGE MANUEL DU PASSAGE DE FUMÉE. Système permettant de maintenir manuellement la propreté des zones où s'effectue l'échange thermique des résidus de combustion, en augmentant ainsi le rendement. Cela garantit un plus grand confort et une consommation de carburant réduite.

Limpieza paso de humos automática

- ES** Durante el funcionamiento se activa de forma automática el sistema de limpieza de los pasos de humos, a través de turbuladores, que hacen caer los residuos de la combustión en el cajón de cenizas. Aumento de la eficiencia y un consumo menor de combustible.
- EN** AUTOMATIC CLEANING PASSAGE SMOKE. During operation the cleaning system of the smoke passages is automatically activated, through turbulators, that cause to drop the residues of the combustion in the box of ashes. Increased efficiency and lower fuel consumption.
- PT** LIMPEZA AUTOMÁTICA DE FUMOS. Durante a operação, ativa automaticamente o sistema de limpeza das condutas de exaustão de gás, através de turbuladores, libertando os resíduos de combustão para a gaveta de cinzas. Maior eficiência e menor consumo de combustível.
- IT** PULIZIA AUTOMATICA PASSAGGIO FUMI. Durante il funzionamento si avvia automaticamente il sistema di pulizia dei passaggi fumi, tramite turbulatori, che fanno cadere i residui della combustione nel cassetto ceneri. Maggiore efficienza e minor consumo di combustibile.
- FR** NETTOYAGE AUTOMATIQUE DU PASSAGE DE FUMÉE. Pendant le fonctionnement le système de nettoyage des passages de fumée est activé automatiquement par le biais de turbulateurs, ce qui entraîne la chute des résidus de combustion dans le cendrier. Efficacité accrue et consommation de carburant réduite.

Grupo Térmico

- ES** La termoestufa y caldera está dotada de un conjunto de elementos hidráulicos como son: vaso de expansión de 8, bomba de circulación electrónica de alta eficiencia, válvula de seguridad de presión a 3 bares, transductor de presión y purgador automático. Todo ello para garantizar al usuario la mayor eficiencia, seguridad y sencillez de instalación.
- EN** THERMAL GROUP The heater is equipped with a set of hydraulic elements, including: 8-litre, depending on the model, high efficiency electronic circulation pump, 3-bar pressure safety valve, pressure transducer and automatic purge. All this to ensure the user the highest efficiency, security and simplicity of installation.
- PT** GRUPO TÉRMICO. A salamandra e caldeira estão equipadas com um conjunto de elementos hidráulicos, tais como: vaso de expansão de 8 litros, a bomba de circulação electrónica de alta eficiência, a válvula de segurança 3 bar, transdutor de pressão e purgador automático. Tudo isto para garantir ao usuário a mais alta eficiência, segurança e simplicidade de instalação.
- IT** GRUPO TÉRMICO. Le termostufe e caldaie sono dotate di componente idraulici che include: vaso di espansione da 8 litri, Pompa elettronica ad alta efficienza, valvola di sicurezza a 3 bar, trasduttore di pressione e valvola automatica di sfogo aria. Tutto questo per garantire all'utente la massima efficienza, sicurezza e facilità di installazione.
- FR** GROUPE THERMIQUE Le thermopêle et chaudière sont dotées de composants hydrauliques tels que ceux qui suivent: vase d'expansion de 8 litres, pompe de circulation électronique à haut rendement, soupape de sécurité de pression 3 bars, transducteur de pression et purgeur automatique. Tout cela pour assurer à l'utilisateur la plus grande efficacité, sécurité et simplicité d'installation.

Limpieza automática del quemador

- ES** El quemador en cada encendido, apagado y durante el funcionamiento hace ciclos de limpieza de forma automática. A través de un sistema de movimiento rotatorio controlado electrónicamente caen las cenizas y los residuos de combustión.
- EN** AUTOMATIC CLEANING BURNER. The burner at every start, stop and during operation cycles cleaning automatically. Ash and combustion residues fall through an electronically controlled rotary movement system.
- PT** LIMPEZA AUTOMÁTICA DO QUEIMADOR. O queimador a cada partida, parada e durante os ciclos de operação limpando automaticamente. As cinzas e os resíduos da combustão caem através de um sistema de movimento rotativo controlado eletronicamente.
- IT** PULIZIA AUTOMATICA BRUCIATORE. Il bruciatore ad ogni accensione, spegnimento e durante il funzionamento effettua cicli di pulizia automatici. Le ceneri e i residui della combustione cadono tramite un sistema di movimento rotatorio a controllo elettronico.
- FR** NETTOYAGE AUTOMATIQUE DU BRÛLEUR. Le brûleur à chaque démarrage, arrêt et pendant le fonctionnement effectue un nettoyage automatique. Les cendres et les résidus de combustion tombent à travers un système de mouvement rotatif à commande électronique.

Cuatro pasos de humo

- ES** Diseñada para obtener un alto rendimiento con un largo recorrido hecho con tres pasos de humos, lo que permite lograr un máximo aprovechamiento del calor generado por la combustión y una elevada eficiencia. Esto garantiza un mayor confort y un menor consumo de combustible.
- EN** FOUR PASSAGES OF SMOKE. Designed to obtain a high performance with a long journey made with three passages of smoke, which allows to achieve a maximum use of heat generated by combustion and high efficiency. This ensures greater comfort and lower fuel consumption.
- PT** QUATRO ETAPAS DE FUMO. Projetado para obter um alto rendimento durante um período longo, executa três etapas de fumo, permitindo alcançar o máximo aproveitamento do calor gerado pela combustão e alta eficiência. Isso garante maior conforto e menor consumo de combustível.
- IT** QUATTRO PASSAGGI FUMI. Disegnata per ottenere un alto rendimento con un lungo percorso fatto con tre passaggi fumi, questo permette di sfruttare al massimo il calore generato dalla combustione e una elevata efficienza. Garanzia di maggior confort e minor consumo di combustibile.
- FR** QUATRE PASSAGE DE FUMÉE. Conçu pour des hautes performances avec un long trajet effectué en trois étapes de fumée et, permettant une utilisation maximale de la chaleur générée par la combustion et un rendement élevé. Cela garantit un plus grand confort et une consommation de carburant réduite.

Sistema de anticondensación

- ES** El innovador diseño del cuerpo de la estufa evita que se produzcan condensaciones que provocan creosota en el interior de los intercambiadores de calor. Este sistema no necesita añadir accesorios de anti-condensación en el circuito hidráulico. Sencillez en la instalación y un mayor confort.
- EN** ANTI-CONDENSATION SYSTEM. The innovative design of the stove body prevents condensation that cause creosote inside the heat exchangers. This system does not need to add anti-condensation accessories in the hydraulic circuit. Simplicity in the installation and greater comfort.
- PT** SISTEMA DE ANTI-CONDENSAÇÃO. O design inovador do corpo da salamandra evita a produção de condensação, o que origina o creosoto no interior dos permutadores de calor. Com este sistema não é necessário adicionar acessórios anti-condensação no circuito hidráulico. Simplicidade na instalação e maior conforto.
- IT** SISTEMA ANTI CONDENSA. L'innovativo disegno del corpo stufa evita che si producano condensate che provocano creosoto all'interno dello scambiatore di calore. Con questo sistema non abbiamo la necessita di montare accessori anti-condensa nel circuito idraulico. Facilita di installazione e maggior confort.
- FR** SYSTÈME ANTI-CONDENSATIONS. La conception innovante du corps de la poêle empêche de la créosote à l'intérieur des échangeurs de chaleur. Ce système n'a pas besoin d'ajouter des accessoires anti-condensation dans le circuit hydraulique. Simplicité d'installation et plus de confort.

Programador Horario

- ES** Sistema que permite programar hasta tres encendidos y tres apagados diarios de forma automática. Se pueden elegir tres maneras diferentes de hacer esta programación: diario, semanal o fin de semana.
- EN** SCHEDULE PROGRAMMER System that allows you to schedule up to three automatic ignitions and shutdowns. This scheduling can be carried out in three different ways: daily, weekly, or weekend.
- PT** PROGRAMADOR HORÁRIO Sistema que permite a programação de até três acendimentos e três apagamentos diários de forma automática.
- IT** PROGRAMMATORE ORARIO. Sistema che permette di programmare fino a tre accensioni e spegnimenti giornalieri automatici della stufa selezionabili in tre diverse impostazioni giornaliero, settimanale e fine settimana.
- FR** PROGRAMMATEUR HORAIRE. Système qui permet de régler jusqu'à trois allumages et trois arrêts quotidiens de façon automatique. Vous pouvez sélectionner trois façons différentes pour effectuer cette programmation: quotidienne, hebdomadaire ou le week-end.

Mando a Distancia

- ES** Todas nuestras estufas están dotadas de mando a distancia que permite el encendido, apagado y regulación de la potencia de combustión sin necesidad de acercarse al equipo.
- EN** REMOTE CONTROL All of our heaters come with a remote control that allows the ignition, shutdown, and regulation of the combustion level without having to touch the equipment.
- PT** COMANDO À DISTÂNCIA Todos os nossos fogões estão dotados de comando a distância que permite o acendimento, apagamento e regulação da potência de combustão, sem necessidade de aproximação ao equipamento.
- IT** COMANDO A DISTANZA. tutte le nostre stufe sono dotate di radio comando a distanza che permette di accendere, spegnere e modificare la potenza di combustione senza necessita' di avvicinarsi all'apparato.
- FR** COMMANDE À DISTANCE Tous nos poêles sont dotés de commande à distance, ce qui permet l'allumage, le débranchement et le réglage de la puissance de combustion, sans avoir besoin de s'approcher de l'équipement.

4 Heat Accesorio Opcional Véase pág. 115

- ES** Con este sistema podemos monitorizar y controlar desde nuestro propio móvil o tablet todas las funciones de la estufa y/o calderas a través de una aplicación compatible con "ANDROID", "IOS" y "Windows PHONE", permitiéndonos esto un mayor confort.
- EN** OPTIONAL 4 HEAT This system allows you to monitor and control all the functions of the heater and/or boiler using your own mobile phone or tablet by using an application compatible with 'ANDROID', 'iOS', and 'Windows PHONE' for ultimate convenience.
- PT** 4 HEAT OPCIONAL Com este sistema podemos monitorizar e controlar, a partir do próprio telemóvel ou tablet, todas as funções do fogão e/ou caldeiras através de uma aplicação compatível com "ANDROID", "IOS" e "Windows PHONE", o que permite um maior conforto.
- IT** 4 HEAT. Sistema che permette di controllare e visualizzare tramite telefono cellulare o Tablet tutte le funzioni della stufa e/o caldaia tramite un'applicazione compatibile con tutti i sistema operativi "ANDROID", "IOS" y "Windows PHONE" permettendo maggior confort.
- FR** 4 HEAT OPTIONNEL Avec ce système, on peut surveiller et contrôler à partir de notre mobile ou tablette toutes les fonctions du poêle et/ou chaudières à travers une application compatible avec «ANDROID» «IOS» et «Windows PHONE», cela nous permettant plus de confort.



Fichas técnicas y manuales en www.ferlux.es

Aire Primario

- ES** Se encuentra en la parte inferior de los aparatos. Nuestros equipos permiten regular esta entrada de aire, según se desee más o menos llama, disminuyendo el consumo de leña y obteniendo una combustión más eficiente.
- EN** PRIMARY AIR. It is located at the bottom of the appliances. Our equipment allows you to regulate this air intake, depending on whether you want more or less flame, reducing the consumption of wood and obtaining a more efficient combustion.
- PT** AR PRIMÁRIO. Ele está localizado na parte inferior dos aparelhos. O nosso equipamento permite regular esta entrada de ar, consoante se pretenda mais ou menos chama, reduzindo o consumo de lenha e obtendo uma combustão mais eficiente.
- IT** ARIA PRIMARIA. Si trova nella parte inferiore degli apparecchi. Questo sistema permette di regolare la presa d'aria, a seconda che si desideri più o meno fiamma, riducendo il consumo di legna e ottenendo una combustione più efficiente.
- FR** AIR PRIMAIRE. Il se trouve au bas de l'appareil. Nos équipements vous permettent de régler cette prise d'air, selon que vous voulez plus ou moins de flamme, en réduisant la consommation de bûches pour ainsi obtenir une combustion plus efficace.

Aire Secundario

- ES** Se encuentra en la parte superior de los equipos. Se trata de un aire precalentado que se introduce en la cámara de combustión favoreciendo la limpieza del cristal, disminuyendo las emisiones en el medio ambiente e incrementando el rendimiento del equipo.
- EN** SECONDARY AIR. It is at the top of the appliances. It is a preheated air that is introduced into the combustion chamber favoring the cleaning of the glass, reducing emissions into the environment and increasing the performance of the equipment.
- PT** AR SECUNDÁRIO. Ele está localizado na parte inferior de dois dispositivos. Nossos equipamentos permitem regular esta entrada de ar, de forma que se pretenda mais ou menos chama, reduzindo o consumo de combustível e obtendo um combustível mais eficiente.
- IT** ARIA SECONDARIA. Si trova nella parte superiore degli apparecchi. È un'aria preriscaldata che viene immessa nella camera di combustione favorendo la pulizia del vetro, riducendo le emissioni nell'ambiente e aumentando le prestazioni delle apparecchiature.
- FR** AIR SECONDAIRE. Il se trouve sur le dessus des équipes. Il s'agit d'un air préchauffé qui est introduit dans la chambre de combustion qui favorise le nettoyage du verre, réduit les émissions dans l'environnement et AUGMENTE LES PERFORMANCES DE L'ÉQUIPEMENT.

Cristal Limpio

- ES** En la parte interna del cristal, una cortina de aire evita que los humos de la combustión entren en contacto con el cristal, garantizando por un largo período de tiempo la visión de la llama y una mejor combustión. También contribuimos a reducir las emisiones y el consumo de combustible.
- EN** CLEAN GLASS. A curtain of air inside the glass prevents the combustion fumes from coming into contact with the glass, thereby guaranteeing a view of the flames and improved combustion for a long period of time. This also helps reduce emissions and fuel consumption.
- PT** VIDRO LIMPO. Na parte interna do vidro, uma cortina de ar evita que os fumos da combustão entrem em contacto com o vidro, garantindo por um longo período de tempo a visão das chamas e uma melhor combustão. Também se contribui para a redução das emissões e do consumo de combustível.
- IT** VETRO PULITO. Una barriera di aria iniettata nella parte interna del vetro evita ai fumi della combustione di entrare in contatto con il cristallo, garantendo una prolungata visione della fiamma e una migliore combustione, dovuta all'apporto di aria preriscaldata nella camera di combustione, base emissioni e minor consumo di combustibile.
- FR** VERRE PROPRE. Au niveau de la partie interne de la vitre, un rideau d'air évite que les fumées de la combustion entrent en contact avec la vitre, ce qui permet de voir la flamme longtemps et une meilleure combustion. Nous contribuons aussi à réduire les émissions et la consommation de combustible.

Doble Combustión

- ES** Se lleva a cabo mediante una inyección de aire precalentado a una altura determinada, reaccionando con los gases inquemados que se desprenden de la combustión. Esto favorece a un mayor rendimiento, un menor consumo de combustible y una reducción de las emisiones al medio ambiente.
- EN** DOUBLE COMBUSTION. It is carried out by an injection of preheated air at a certain height, reacting with the unburned gases that are released from combustion. This favors higher performance, lower fuel consumption and reduced emissions to the environment.
- PT** COMBUSTÃO DUPLA. É realizado por uma injeção de ar pré-aquecido a uma certa altura, reagindo com os gases não queimados que são liberados da combustão. Isso favorece maior desempenho, menor consumo de combustível e emissões reduzidas para o meio ambiente.
- IT** DOPPIA COMBUSTIONE. Viene effettuato mediante iniezione di aria preriscaldata ad una certa altezza, reagendo con i gas incombusti che si liberano dalla combustione. Ciò favorisce prestazioni più elevate, minori consumi di carburante e minori emissioni nell'ambiente.
- FR** DOUBLE COMBUSTION. Elle se fait au moyen d'une injection d'air préchauffé à une certaine hauteur, réagissant avec les gaz non brûlés qui sont libérés de la combustion. Cela permet des performances plus élevées, une consommation de carburant plus faible et des émissions réduites dans l'environnement.

Triple Combustión

- ES** Sistema con el que se produce una tercera combustión de los gases inquemados en la primera y segunda combustión, incrementando el rendimiento, reduciendo el consumo de combustible y disminuyendo radicalmente las emisiones en el medio ambiente.
- EN** TRIPLE COMBUSTION. System that produces a third combustion of the unburned gases in the first and second combustion, increasing performance, reducing fuel consumption and radically reducing emissions into the environment.
- PT** COMBUSTÃO TRIPLA. Sistema com o qual uma terceira combustão dos gases não queimados é produzida na primeira e na segunda combustão, aumentando o desempenho, reduzindo o consumo de combustível e reduzindo radicalmente as emissões para o meio ambiente.
- IT** TRIPLA COMBUSTIONE. Sistema con il quale si produce una terza combustione dei gas incombusti nella prima e seconda combustione, aumentando le prestazioni, riducendo i consumi di carburante e riducendo radicalmente le emissioni nell'ambiente.
- FR** TRIPLE COMBUSTION. Système avec lequel se produit une troisième combustion des gaz non brûlés lors de la première et la deuxième combustion, pour augmenter les performances, réduire la consommation de carburant et ainsi baisser radicalement les émissions dans l'environnement.

Regulador de Tiro

- ES** Se encuentra en la parte superior de los aparatos. Los equipos que lo incorporan permiten regular el tiro de la salida de humos, disminuyendo el consumo de leña y aumentando la eficiencia.
- EN** SMOKE DRAFT REGULATOR. It is located on top of the appliances. The equipment that incorporates it allows to regulate the draft of the smoke outlet, reducing the consumption of firewood and increasing efficiency.
- PT** REGULADOR DE TIRO. Ele está localizado na parte superior dos aparelhos. O equipamento que o incorpora permite regular a tiragem da saída de fumos, reduzindo o consumo de lenha e aumentando a eficiência.
- IT** REGOLATORE DI TIRAGIO. Si trova nella parte superiore degli apparati. Dando la possibilità di regolare il tiraggio della canna fumaria, riducendo il consumo della legna e aumentando l'efficienza.
- FR** REGULATEUR DE TIRAGE. Il est situé au-dessus des appareils. L'équipement qui l'intègre permet de réguler le tirage de la sortie de fumée, de réduire la consommation de bois de chauffage et d'augmenter l'efficacité.

Cristal Serigrafiado

- ES** Los aparatos que lo incorporan presentan un diseño más elegante y sofisticado, consiguiendo que la puerta no sea simplemente un componente técnico sino que a su vez sea un elemento decorativo.
- EN** SCREEN PRINTED GLASS. The appliances that incorporate it present a more elegant and sophisticated design, ensuring that the door is not simply a technical component but is also a decorative element.
- PT** VIDRO IMPRESO. Os aparelhos que a incorporam apresentam um design mais elegante e sofisticado, garantindo que a porta não seja apenas um componente técnico, mas também um elemento decorativo.
- IT** CRISTALLO SERIGRAFIATO. I prodotti che lo incorporano hanno un design più elegante e sofisticato, facendo sì che la porta non sia semplicemente un componente tecnico, ma anche un elemento decorativo.
- FR** VERRE IMPRIMÉ. Les appareils qui l'intègrent présentent un design plus élégant et sophistiqué, garantissant que la porte n'est pas simplement un élément technique, mais aussi un élément décoratif.

Vermiculita Blanca

- ES** El color blanco permite una atractiva visión de la llama. Los aparatos que la incorporan tienen la cámara de combustión completamente recubierta de vermiculita (material resistente a las altas temperaturas y al contacto prolongado de la llama). Siendo un material altamente refractario, garantiza una combustión completa disminuyendo las emisiones a la atmósfera gracias a las altas temperaturas que alcanza la cámara de combustión.
- EN** WHITE VERMICULITE. The white color allows an attractive view of the flame. The devices that incorporate it have the combustion chamber completely covered with vermiculite (a material resistant to high temperatures and prolonged contact with the flame). Being a highly refractory material, it guarantees complete combustion, reducing emissions to the atmosphere thanks to the high temperatures that the combustion chamber reaches.
- PT** VERMICULITE BRANCA. A cor branca permite uma visão atrativa da chama. Os aparelhos que o incorporam têm a câmara de combustão totalmente coberta com vermiculita (material resistente a altas temperaturas e contato prolongado com a chama). Por ser um material altamente refratário, garante uma combustão completa, reduzindo as emissões para a atmosfera graças às altas temperaturas que atinge a câmara de combustão.
- IT** VERMICULITE BIANCA. Il colore bianco permette un'attraente visione della fiamma. I dispositivi che lo incorporano hanno la camera di combustione completamente ricoperta di vermiculite (un materiale resistente alle alte temperature e al contatto prolungato con la fiamma). Essendo un materiale altamente refrattario, garantisce una combustione completa, riducendo le emissioni in atmosfera grazie alle alte temperature che permette di raggiungere alla camera di combustione.
- FR** VERMICULITE BLANCHE. La couleur blanche permet une vue attirant de la flamme. Les appareils qui l'intègrent ont la chambre de combustion entièrement recouverte de ce matériau qui est résistant aux températures élevées et au contact prolongé avec la flamme. Étant un matériau hautement réfractaire, il garantit une combustion complète, réduisant les émissions dans l'atmosphère grâce aux températures élevées que la chambre de combustion atteint.

Vermiculita

- ES** Los aparatos que la incorporan tienen la cámara de combustión completamente recubierta de vermiculita (material resistente a las altas temperaturas y al contacto prolongado de la llama). Siendo un material altamente refractario, garantiza una combustión completa disminuyendo las emisiones a la atmósfera gracias a las altas temperaturas que alcanza la cámara de combustión.
- EN** VERMICULITE. The devices that incorporate it have the combustion chamber completely covered with vermiculite (a material resistant to high temperatures and prolonged contact with the flame). Being a highly refractory material, it guarantees complete combustion, reducing emissions to the atmosphere thanks to the high temperatures that the combustion chamber reaches.
- PT** VERMICULITE. Os aparelhos que o incorporam têm a câmara de combustão totalmente coberta com vermiculita (material resistente a altas temperaturas e contato prolongado com a chama). Por ser um material altamente refratário, garante uma combustão completa, reduzindo as emissões para a atmosfera graças às altas temperaturas que atinge a câmara de combustão.
- IT** VERMICULITE. I dispositivi che lo incorporano hanno la camera di combustione completamente ricoperta di vermiculite (un materiale resistente alle alte temperature e al contatto prolungato con la fiamma). Essendo un materiale altamente refrattario, garantisce una combustione completa, riducendo le emissioni in atmosfera grazie alle alte temperature che permette di raggiungere alla camera di combustione.
- FR** VERMICULITE. Les appareils qui l'intègrent ont la chambre de combustion entièrement recouverte de ce matériau qui est résistant aux températures élevées et au contact prolongé avec la flamme. Étant un matériau hautement réfractaire, il garantit une combustion complète, réduisant les émissions dans l'atmosphère grâce aux températures élevées que la chambre de combustion atteint.



Interior de Cerámica Refractaria

- ES** El material refractario que incorporan algunos de nuestros modelos en la cámara de combustión proporciona un toque elegante y luminosidad al hogar. Además, es notoria su capacidad para retener el calor e incrementar el rendimiento durante la combustión.
- EN** REFRACTORY INTERIOR The heat-resistant material featured in the combustion chamber of some of our models provides the home with an elegant and luminous touch. Furthermore, the fact this material retains heat and increases performance during the combustion process is well known.
- PT** INTERIOR EM MATERIAL REFRATÁRIO O material refratário que alguns dos nossos modelos incorporam na câmara de combustão proporciona um toque elegante e luminosidade à casa. Além disso, é notória a sua capacidade de retenção do calor e de aumento do rendimento durante a combustão.
- IT** CAMERA DI COMBUSTIONE IN REFRATTARIO La camera di combustione in refrattario presente in alcuni modelli rende il caminetto piu' luminoso ed elegante. Inoltre questo materiale accumulando il calore aumenta il rendimento della combustione.
- FR** INTÉRIEUR EN MATÉRIAU RÉFRACTAIRE. Le matériau réfractaire inclus dans certains de nos modèles au niveau de la chambre de combustion donne une touche élégante et une luminosité au foyer. De plus, sa capacité de rétention de la chaleur et d'augmentation du rendement pendant la combustion est notoire.



Interior en Fundición

- ES** Los modelos que equipan una cámara de combustión en hierro fundido tienen la gran ventaja de soportar perfectamente las altas temperaturas y retener el calor durante más tiempo, sin sufrir dilataciones ni daños.
- EN** CAST IRON INTERIOR Models equipped with a cast iron combustion chamber have the great advantage of fully withstanding high temperatures and retaining heat for longer without expanding or suffering any damage.
- PT** INTERIOR EM FERRO FUNDIDO. Os modelos que estão dotados de câmara de combustão em ferro fundido têm a grande vantagem de suportarem perfeitamente as altas temperaturas e reterem o calor durante mais tempo, sem sofrerem dilatações nem danos.
- IT** CAMERA DI COMBUSTIONE IN GHISA I modelli dotati di camera di combustione in ghisa hanno il vantaggio di sopportare le alte temperature e accumula il calore per lungo periodo
- FR** INTÉRIEUR EN FONTE Les modèles équipés d'une chambre de combustion en fonte présentent le grand avantage de supporter parfaitement les hautes températures et de retenir la chaleur plus longtemps, sans souffrir de dilatations ou dommages.



Equipo Estanco

- ES** Los equipos estancos no consumen el aire de la estancia en la que se encuentran instalados. Al no saturar el ambiente ni reducir la cantidad de oxígeno en este, permite un mayor confort.
- EN** CLOSED MODEL. Airtight equipment does not consume the air from the room in which it is installed. This ensures greater comfort due to the fact the environment is not saturated and the amount of oxygen in the room is not diminished.
- PT** EQUIPAMENTO ESTANQUE Os equipamentos estanques não consomem o ar do compartimento em que estão instalados. Pelo facto de não saturarem o ambiente nem reduzirem a quantidade de oxigénio neste, permitem um maior conforto.
- IT** MODELLI ERMETICI I modelli ermetici non prelevano l'aria della stanza dove sono installati bensì dall'esterno, questo rende l'ambiente piu' salutare aumentando il confort.
- FR** ÉQUIPEMENT ÉTANCHE Les équipements étanches ne consomment pas l'air de la pièce dans laquelle ils sont installés. Ne saturant pas l'atmosphère et ne réduisant pas la quantité d'oxygène dans cette pièce, il permet d'avoir un plus grand confort.



Aire Exterior

- ES** Los equipos que cuentan con una entrada de aire exterior permiten que la chimenea trabaje de una forma más eficiente, puesto que se utiliza aire frío con mayor concentración de oxígeno y nitrógeno para la combustión. Ello implica una reducción en el consumo de leña.
- EN** OUTSIDE AIR Equipment featuring an outside air inflow enables the fireplace to work more efficiently, as it uses cold air with a greater concentration of oxygen and nitrogen in the combustion process. This means a reduction in the consumption of wood.
- PT** AR EXTERIOR Os equipamentos que têm uma entrada de ar exterior permitem que a chaminé trabalhe de uma forma mais eficiente, dado que se utiliza ar frio com uma maior concentração de oxigénio e nitrogénio para a combustão. Isso implica uma redução do consumo de lenha.
- IT** ARIA ESTERNA I modelli dotati di entrata di aria esterna risultano molto piu' efficienti, l'aria fredda ha una maggiore concentrazione di ossigeno e nitrógeno necessari per la combustione. Questo permette un risparmio di legna.
- FR** AIR EXTÉRIEUR Les équipements qui disposent d'une entrée d'air extérieur permettent à la cheminée de travailler d'une manière plus efficace, car on utilise de l'air froid avec une plus grande concentration en oxygène et azote pour la combustion. Cela permet de réduire la consommation de bois de chauffage



Turbina

- ES** A la capacidad calefactora por convección natural de todos nuestros equipos, hay que sumar el efecto de las turbinas de impulsión con las que cuentan algunos de ellos. Especialmente indicados en caso de necesitar una canalización del aire caliente mejorando el confort en habitaciones contiguas.
- EN** TURBINE In addition to the heating process using natural convection, some of our equipment boasts the advantages of impulse turbines. Specifically recommended in the event of the need for channeling hot air, thereby improving comfort in adjoining rooms.
- PT** TURBINA À capacidade de aquecimento por convecção natural de todos os nossos equipamentos, deve-se somar o efeito das turbinas de impulsão que alguns deles têm. Especialmente indicados em caso de necessidade de uma canalização do ar quente, melhorando o conforto em compartimentos contíguos.
- IT** TURBINA Tutti i nostri modelli riscaldano per convezione, in alcuni modelli si puo' aggungere il ventilatore per aria calda. Indicato per canalizzare l'aria calda aumentando il confort nei local attigui.
- FR** TURBINE À la capacité de chauffage par convection naturelle de tous de nos équipements, il faut ajouter l'effet des turbines à impulsion dont disposent certains d'entre eux. Spécialement indiqués si l'on a besoin d'une canalisation d'air chaud améliorant le confort dans les pièces contiguës.



Potenciómetro

- ES** Permite activar - desactivar el sistema de aire por turbinas que incorpora el aparato proporcionando al usuario la regulación de la cantidad de flujo de aire deseado.
- EN** POTENTIOMETER. It allows activating - deactivating the turbine air system that the device incorporates, providing the user with the regulation of the desired air flow quantity.
- PT** POTENCIÓMETRO. Permite ativar - desativar o sistema de ar da turbina que o dispositivo incorpora, proporcionando ao usuário a regulagem da quantidade de fluxo de ar desejada.
- IT** POTENZIOMETRO. Permette di attivare - disattivare il sistema d'aria della turbina che il dispositivo incorpora, fornendo all'utente la regolazione della quantità di flusso d'aria desiderata.
- FR** POTENTIOMÈTRE. Il permet d'activer ou désactiver le système d'air de la turbine intégré dans le dispositif, fournissant à l'utilisateur le réglage de la quantité d'air souhaitée.

Canalización

- ES** Sistema que permite llevar aire caliente a través de conductos a otras estancias mediante turbinas muy silenciosas. Esto garantiza un mayor confort y un menor consumo de combustible.
- EN** CANALISATION. Système qui permet d'amener de l'air chaud par des conduits vers d'autres pièces au moyen de turbines très silencieuses. Cela garantit un plus grand confort et une consommation de carburant moindre.
- PT** CANALIZAÇÃO. Sistema que permite levar ar quente através de dutos para outras salas por meio de turbinas muito silenciosas. Isso garante maior conforto e menor consumo de combustível.
- IT** CANALIZZAZIONE. Sistema che permette di portare aria calda attraverso condotti ad altri ambienti mediante turbine molto silenziose. Ciò garantisce un maggiore comfort e un minor consumo di carburante.
- FR** CANALISATION. Système qui permet d'amener de l'air chaud par des conduits vers d'autres pièces au moyen de turbines très silencieuses. Cela garantit un plus grand confort et une consommation de carburant moindre.



Regulable en Altura

- ES** Los modelos que cuentan con patas regulables en altura permiten una perfecta nivelación y asiento del equipo en la superficie en la que se instale, facilitando la labor del instalador y mejorando el ajuste del equipo en el revestimiento.
- EN** ADJUSTABLE HEIGHT Models fitted with adjustable legs ensure the equipment is perfectly level and stable on the surface on which it is installed, thereby facilitating the work of the installer and the adaptation of the equipment to the lining.
- PT** REGULÁVEL EM ALTURA Os modelos que têm pés reguláveis em altura permitem um perfeito nivelamento e assentamento do equipamento na superfície em que seja instalado, facilitando o trabalho do instalador e melhorando o ajuste do equipamento no revestimento.
- IT** REGOLABILI IN ALTEZA I modelli dotati di piedi regolabili in altezza permettono una perfetta livellazione anche su superfici non piane. Facilitano il lavoro di messa in opera e il montaggio del rivestimento
- FR** RÉGLABLE EN HAUTEUR Les modèles disposant de pieds réglables en hauteur permettent un nivellement parfait de l'équipement sur la surface où il est installé, ce qui facilite la tâche de l'installateur et le réglage de l'équipement sur le revêtement.



Fichas técnicas y manuales en

www.ferlux.es



GAMAPELLET



AIRE
CANALIZABLE
AGUA
CALDERAS



G A M A A I R E

Con una variedad de productos respecto a la potencia, dimensiones y diseño que se adaptan fácilmente en cualquier ambiente. Pensadas para dar el máximo confort, gracias al sistema Air Silence y a la posibilidad de elegir la temperatura deseada.

- SHARA
- ARES
- HELEN GLASS
- HELEN STEEL
- ELISA
- NEREA
- VENUS
- NATALIA
- LUNA
- AROA
- GENESIS GLASS
- GENESIS STEEL
- MAIA
- FLORA
- FLORA SV
- GENESIS GLASS
- GENESIS STEEL
- IRIS
- NEREA
- ESTELA
- ULYSES

SHARA

6 Kw | 8 Kw | 10 Kw

A+

Kw Total	6,8 Kw 9,3 Kw 10,8 Kw	Min-Max	94 - 90 % 94 - 88 % 94 - 88 %	Min-Max	35 - 15 h 35 - 11 h 35 - 10 h	mm	40 mm
Kw Nominal	6,1 Kw 8,2 Kw 9,5 Kw	Kg	125 Kg	Kg/h Min-Max	0,6 - 1,4 0,6 - 1,9 0,6 - 2,2	m³	150 m ³ 195 m ³ 245 m ³
Kw Min-Max	2,8 - 6,1 Kw 2,8 - 8,2 Kw 2,8 - 9,5 Kw	Kg	21 Kg	mm	474 x 530 x 985	mm	80 mm



- Blanco perla**
White pearl
Branco pérola
Bianco perla
Perle blanche
- Rojo imperial**
Imperial red
Bermelho imperial
Rosso imperiale
Rouge impériale
- Negro**
Black
Negro
Nero
Noir
- Marrón vintage**
Vintage brown
Marron vintage
Marrone vintage
Marron vintage

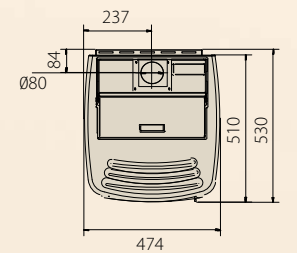
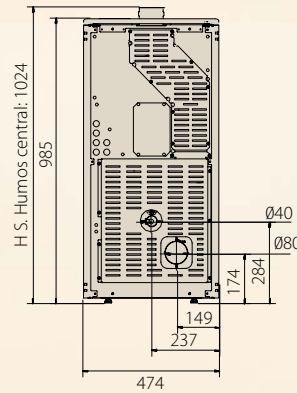

Accesorio opcional:
Salida de humo vertical
MODELO A
Véase pág. 114



Tapa en fundición

Puerta y rejilla en fundición

ARES

6 Kw | 8 Kw | 10 Kw

A+

Kw Total	6,9 Kw 9,3 Kw 11,2 Kw	Min-Max	94 - 91 % 94 - 90 % 94 - 88 %	Min-Max	30 - 15 h 30 - 11 h 30 - 9 h	mm	40 mm
Kw Nominal	6,3 Kw 8,5 Kw 10,2 Kw	Kg	122 Kg	Kg/h Min-Max	0,7 - 1,4 0,7 - 1,9 0,7 - 2,3	m³	150 m ³ 195 m ³ 245 m ³
Kw Min-Max	3,4 - 6,3 Kw 3,4 - 8,5 Kw 3,4 - 10,2 Kw	Kg	21 Kg	mm	700 x 571 x 805	mm	80 mm



- Blanco perla**
White pearl
Branco pérola
Bianco perla
Perle blanche
- Rojo imperial**
Imperial red
Bermelho imperial
Rosso imperiale
Rouge impériale
- Negro**
Black
Negro
Nero
Noir
- Marrón vintage**
Vintage brown
Marron vintage
Marrone vintage
Marron vintage

Puerta en cristal serigrafiado

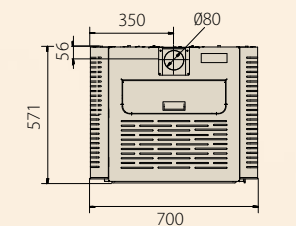
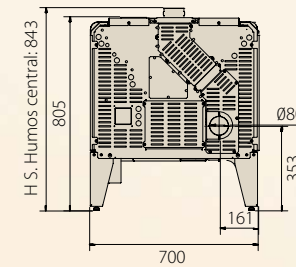

Accesorio opcional:
Salida de humo vertical
MODELO B
Véase pág. 114



OPCIONAL



OPCIONAL

HELENGLASS

6 Kw | 8 Kw | 10 Kw

A+

Kw Total	6,8 Kw 9,3 Kw 10,8 Kw	Min-Max	94 - 90 % 94 - 88 % 94 - 88 %	Min-Max	35 - 15 h 35 - 11 h 35 - 10 h	mm	40 mm
Kw Nominal	6,1 Kw 8,2 Kw 9,5 Kw	Kg	115 Kg	Kg/h Min-Max	0,6 - 1,4 0,6 - 1,9 0,6 - 2,2	m³	150 m ³ 195 m ³ 245 m ³
Kw Min-Max	2,8 - 6,1 Kw 2,8 - 8,2 Kw 2,8 - 9,5 Kw	Kg	21 Kg	mm	550 x 608 x 978	mm	80 mm

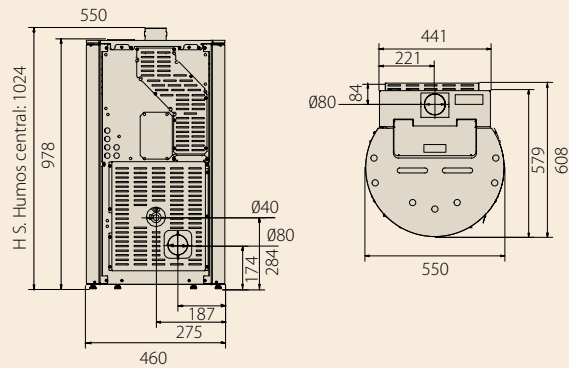

Doble puerta

Puerta exterior con efecto magic, en cristal fotocromático, ofreciendo visión de fuego una vez encendida.
Puerta interior de seguridad.
Laterales y tapa en cristal serigrafado.



Accesorio opcional:
Salida de humo vertical
MODELO A
Véase pág. 114



OPCIONAL



HELENSTEEL

6 Kw | 8 Kw | 10 Kw

A+

Kw Total	6,8 Kw 9,3 Kw 10,8 Kw	Min-Max	94 - 90 % 94 - 88 % 94 - 88 %	Min-Max	35 - 15 h 35 - 11 h 35 - 10 h	mm	40 mm
Kw Nominal	6,1 Kw 8,2 Kw 9,5 Kw	Kg	118 Kg	Kg/h Min-Max	0,6 - 1,4 0,6 - 1,9 0,6 - 2,2	m³	150 m ³ 195 m ³ 245 m ³
Kw Min-Max	2,8 - 6,1 Kw 2,8 - 8,2 Kw 2,8 - 9,5 Kw	Kg	21 Kg	mm	550 x 608 x 978	mm	80 mm



Blanco perla
White pearl
Bianco pérola
Perle blanche

Negro
Black
Nero
Noir

Marrón vintage
Vintage brown
Marrom vintage
Marrone vintage
Marron vintage

Rojo imperial
Imperial red
Bermelho imperial
Rosso imperiale
Rouge impériale

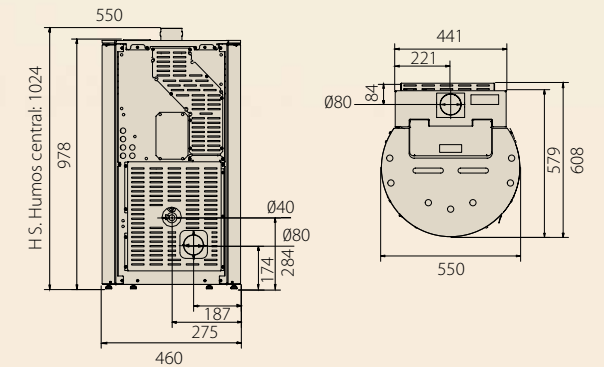

Doble puerta

Puerta exterior con efecto magic, en cristal fotocromático, ofreciendo visión de fuego una vez encendida.
Puerta interior de seguridad.
Laterales y tapa en acero pintado.



Accesorio opcional:
Salida de humo vertical
MODELO A
Véase pág. 114



OPCIONAL



ELISA

6 Kw | 8 Kw | 10 Kw

A+



Kw Total	6,8 Kw 9,3 Kw 10,8 Kw	Kg	126 Kg	mm	474 x 530 x 985
Kw Nominal	6,1 Kw 8,2 Kw 9,5 Kw	Kg	21 Kg	mm	40 mm
Kw Min-Max	2,8 - 6,1 Kw 2,8 - 8,2 Kw 2,8 - 9,5 Kw	Min-Max	35 - 15 h 35 - 11 h 35 - 10 h	m³	150 m³ 195 m³ 245 m³
Min-Max	94 - 90 % 94 - 88 % 94 - 88 %	Kg/h Min-Max	0,6 - 1,4 0,6 - 1,9 0,6 - 2,2	mm	80 mm



NEREA

8 Kw | 10 Kw

A+



Kw Total	9,3 Kw 10,8 Kw	Kg	110 Kg	mm	450 x 497 x 985
Kw Nominal	8,2 Kw 9,5 Kw	Kg	22 Kg	mm	40 mm
Kw Min-Max	2,8 - 8,2 Kw 2,8 - 9,5 Kw	Min-Max	37 - 12 h 37 - 10 h	m³	195 m³ 245 m³
Min-Max	94 - 88 % 94 - 88 %	Kg/h Min-Max	0,6 - 1,9 0,6 - 2,2	mm	80 mm

FERLUX . E S



- Blanco perla**
White pearl
Branco pérola
Bianco perla
Perle blanche
- Rojo imperial**
Imperial red
Bermelho imperial
Rosso imperiale
Rouge impériale
- Negro**
Black
Negro
Nero
Noir
- Marrón vintage**
Vintage brown
Marrom vintage
Marrone vintage
Marron vintage

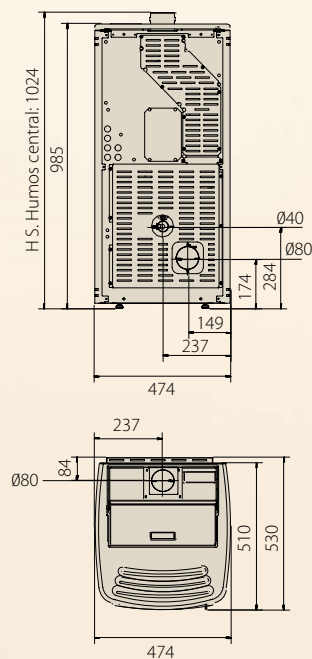

Accesorio opcional:
Salida de humo vertical
MODELO A
Véase pág. 114



Tapa en fundición



Puerta y rejilla en fundición



Puerta y rejilla en fundición

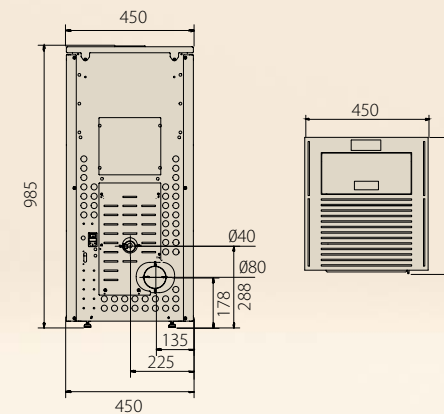

- Blanco perla**
White pearl
Branco pérola
Bianco perla
Perle blanche
- Rojo imperial**
Imperial red
Bermelho imperial
Rosso imperiale
Rouge impériale
- Negro**
Black
Negro
Nero
Noir
- Marrón vintage**
Vintage brown
Marrom vintage
Marrone vintage
Marron vintage



VENUS

6 Kw | 8 Kw | 10 Kw

A+

Kw Total	6,8 Kw 9,3 Kw 10,8 Kw	Min-Max	94 - 90 % 94 - 88 % 94 - 88 %	Min-Max	35 - 15 h 35 - 11 h 35 - 10 h	mm	40 mm
Kw Nominal	6,1 Kw 8,2 Kw 9,5 Kw	Kg	103 Kg	Kg/h Min-Max	0,6 - 1,4 0,6 - 1,9 0,6 - 2,2	m³	150 m ³ 195 m ³ 245 m ³
Kw Min-Max	2,8 - 6,1 Kw 2,8 - 8,2 Kw 2,8 - 9,5 Kw	Kg	21 Kg	mm	437 x 530 x 1006	mm	80 mm



NATALIA

10 Kw

A+

Kw Total	10,8 Kw	Min-Max	94 - 88 %	Min-Max	37 - 10 h	mm	40 mm
Kw Nominal	9,5 Kw	Kg	110 Kg	Kg/h Min-Max	0,6 - 2,2	m³	245 m ³
Kw Min-Max	2,8 - 9,5 Kw	Kg	22 Kg	mm	452 x 498 x 985	mm	80 mm



- Blanco perla**
White pearl
Branco pérola
Bianco perla
Perle blanche
- Rojo imperial**
Imperial red
Bermelho imperial
Rosso imperiale
Rouge impériale
- Negro**
Black
Negro
Nero
Noir
- Marrón vintage**
Vintage brown
Marron vintage
Marrone vintage
Marron vintage

Puerta en cristal serigrafiado

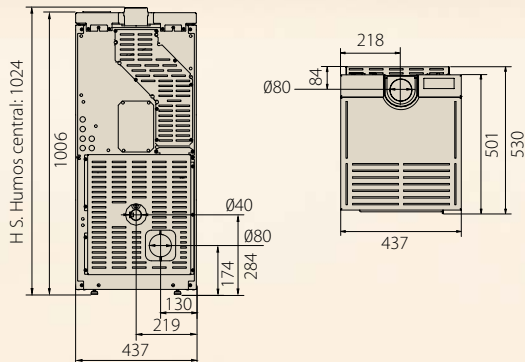

Tapa deslizante para carga de pellet



Accesorio opcional:
Salida de humo vertical
MODELO A
Véase pág. 114

OPCIONAL

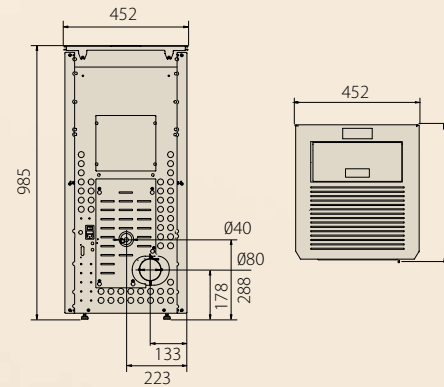

Puerta y rejilla en fundición



- Blanco perla**
White pearl
Branco pérola
Bianco perla
Perle blanche
- Rojo imperial**
Imperial red
Bermelho imperial
Rosso imperiale
Rouge impériale
- Marrón vintage**
Vintage brown
Marron vintage
Marrone vintage
Marron vintage

OPCIONAL



LUNA

8 Kw | 10 Kw

A+

Kw Total	9,3 Kw 10,8 Kw	94 - 88 % Min-Max 94 - 88 %	37 - 12 h Min-Max 37 - 10 h	40 mm
Kw Nominal	8,2 Kw 9,5 Kw	110 Kg	Kg/h Min-Max 0,6 - 1,9 0,6 - 2,2	195 m ³ 245 m ³
Kw Min-Max	2,8 - 8,2 Kw 2,8 - 9,5 Kw	22 Kg	606 x 504 x 1121 mm	80 mm

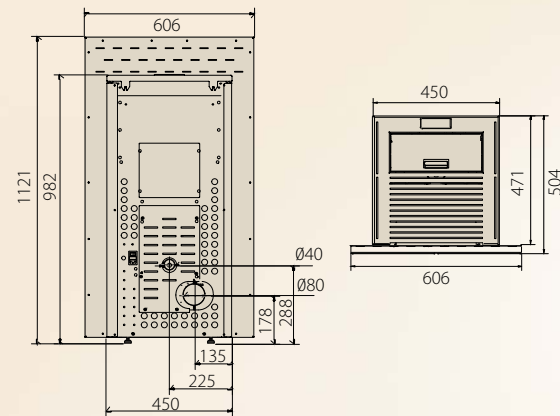

Puerta en cristal serigrafiado



Blanco perla
White pearl | Branco pérola
Bianco perla | Perle blanche

Marrón vintage
Marron vintage | Vintage brown
Marrone vintage | Marron vintage



AROA

8 Kw | 10 Kw

A+

Kw Total	9,3 Kw 10,8 Kw	94 - 88 % Min-Max 94 - 88 %	43 - 14 h Min-Max 43 - 12 h	40 mm
Kw Nominal	8,2 Kw 9,5 Kw	110 Kg	Kg/h Min-Max 0,6 - 1,9 0,6 - 2,2	195 m ³ 245 m ³
Kw Min-Max	2,8 - 8,2 Kw 2,8 - 9,5 Kw	26 Kg	460 x 498 x 1053 mm	80 mm



Puerta en cristal serigrafiado

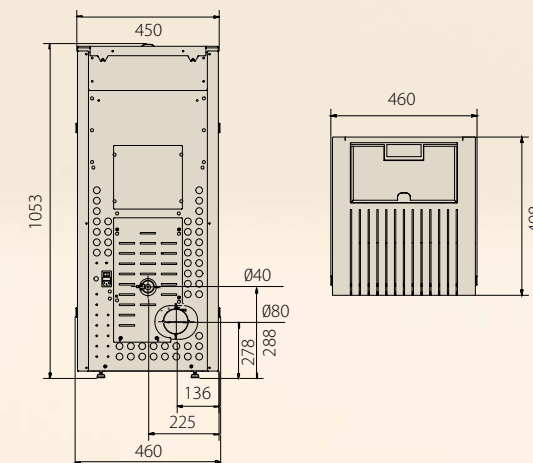

Negro
Black
Negro
Nero

Blanco perla
White pearl
Branco pérola
Bianco perla
Perle blanche

Marrón vintage
Vintage brown
Marron vintage
Marrone vintage
Marron vintage





GÉNESIS GLASS

6 Kw | 8 Kw

A++

Kw Total 6,5 Kw 8,8 Kw	96 - 93 % Min-Max 96 - 92 %	40 - 15 h Min-Max 40 - 11 h	40 mm
Kw Nominal 6,2 Kw 8,1 Kw	120 Kg	Kg/h 0,5 - 1,3 Min-Max 0,5 - 1,8	150 m³ 195 m ³
Kw Min-Max 2,4 - 6,2 Kw 2,4 - 8,1 Kw	20 Kg	897 x 295 x 1086 mm	80 mm

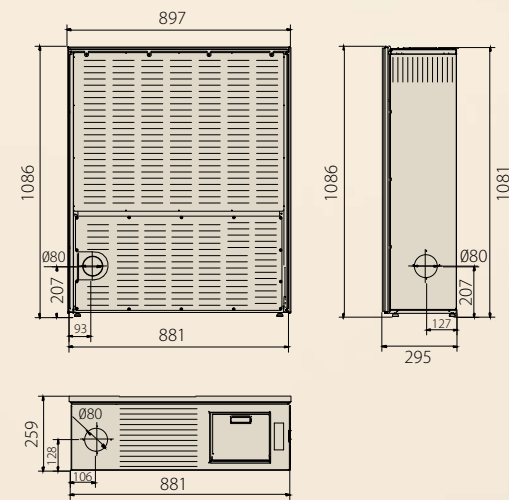

Puerta y frontal en cristal serigrafiado



POSIBLES CONEXIONES DE SALIDA DE HUMOS

- A. Salida superior
- B. Salida trasera
- C. Salida lateral derecho



GÉNESIS STEEL

6 Kw | 8 Kw

A++

Kw Total 6,5 Kw 8,8 Kw	96 - 93 % Min-Max 96 - 92 %	40 - 15 h Min-Max 40 - 11 h	40 mm
Kw Nominal 6,2 Kw 8,1 Kw	120 Kg	Kg/h 0,5 - 1,3 Min-Max 0,5 - 1,8	150 m³ 195 m ³
Kw Min-Max 2,4 - 6,2 Kw 2,4 - 8,1 Kw	20 Kg	897 x 295 x 1086 mm	80 mm

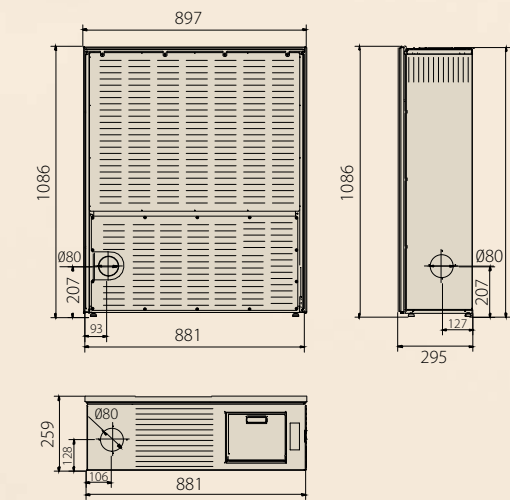

Puerta en cristal serigrafiado

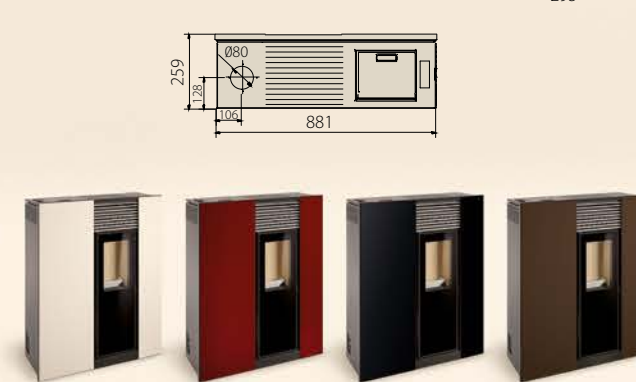

- Blanco perla**
White pearl
Branco pérola
Bianco perla
Perle blanche
- Rojo imperial**
Imperial red
Bermelho imperial
Rosso imperiale
Rouge impériale
- Negro**
Black
Negro
Nero
Noir
- Marrón vintage**
Vintage brown
Marron vintage
Marrone vintage
Marron vintage

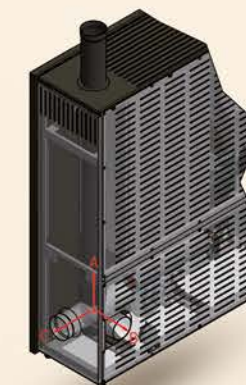

POSIBLES CONEXIONES DE SALIDA DE HUMOS

- A. Salida superior
- B. Salida trasera
- C. Salida lateral derecho



MAIA

6 Kw | 8 Kw

A++

Kw Total	6,5 Kw 8,8 Kw	96 - 93% Min-Max 96-92%	27 - 10 h Min-Max 27 - 8 h	40 mm
Kw Nominal	6,2 Kw 8,1 Kw	107 Kg	Kg/h	150 m³ 195 m ³
Kw Min-Max	2,4 - 6,2 Kw 2,4 - 8,1 Kw	13,5 Kg	800 x 259 x 1046 mm	80 mm



MAIA

10 Kw

A+

Kw Total	11,3 Kw	96 - 91 % Min-Max	27 - 6 h Min-Max	40 mm
Kw Nominal	10,1 Kw	107 Kg	Kg/h	245 m³ Min-Max
Kw Min-Max	2,4 - 10,1 Kw	13,5 Kg	800 x 259 x 1046 mm	80 mm



FERLUX . E S

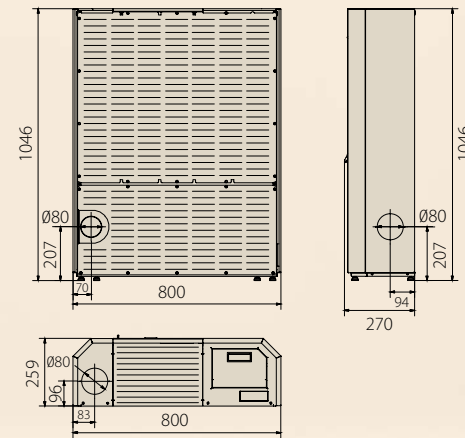

Puerta en cristal serigrafiado



- | | | | |
|--|---|--|---|
| Blanco perla
White pearl
Branco pérola
Bianco perla
Perle blanche | Rojo imperial
Imperial red
Bermelho imperial
Rosso imperiale
Rouge impériale | Negro
Black
Negro
Nero
Noir | Marrón vintage
Vintage brown
Marron vintage
Marrone vintage
Marron vintage |
|--|---|--|---|

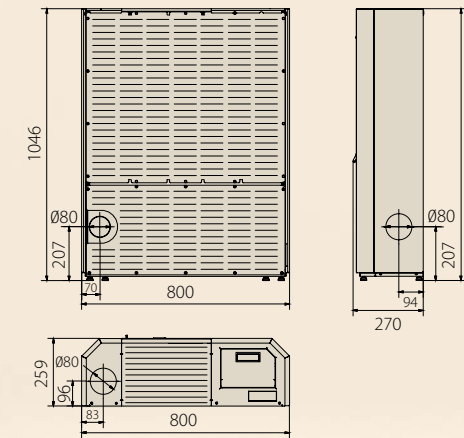

Puerta en cristal serigrafiado



- | | | | |
|--|---|--|---|
| Blanco perla
White pearl
Branco pérola
Bianco perla
Perle blanche | Rojo imperial
Imperial red
Bermelho imperial
Rosso imperiale
Rouge impériale | Negro
Black
Negro
Nero
Noir | Marrón vintage
Vintage brown
Marron vintage
Marrone vintage
Marron vintage |
|--|---|--|---|

OPCIONAL



OPCIONAL



FLORA

7 Kw | 8 Kw

A+

Kw Total	7,9 Kw 9,3 Kw	Kg	95 Kg	mm	458 x 499 x 917
Kw Nominal	7,1 Kw 8,2 Kw	Kg	17 Kg	mm	40 mm
Kw Min-Max	2,8 - 7,1 Kw 2,8 - 8,2 Kw	Min-Max	28 - 11 h 28 - 9 h	m³	165 m³ 195 m³
Min-Max	94 - 90 % 94 - 88 %	Kg/h Min-Max	0,6 - 1,6 0,6 - 1,9	mm	80 mm



FLORA

SALIDA VERTICAL

8 Kw | 10 Kw

A+

Kw Total	9,3 Kw 10,8 Kw	Kg	95 Kg	mm	480 x 529 x 917
Kw Nominal	8,2 Kw 9,5 Kw	Kg	12 Kg	mm	40 mm
Kw Min-Max	2,8 - 8,2 Kw 2,8 - 9,5 Kw	Min-Max	20 - 6 h 20 - 5 h	m³	195 m³ 245 m³
Min-Max	94 - 88 % 94 - 88 %	Kg/h Min-Max	0,6 - 1,9 0,6 - 2,2	mm	80 mm

FERLUX . ES



Puerta y rejilla en fundición

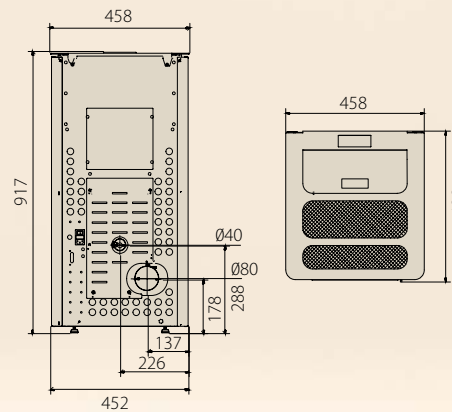

Blanco perla
White pearl
Branco pérola
Bianco perla
Perle blanche

Rojo imperial
Imperial red
Bermelho imperial
Rosso imperiale
Rouge impériale

Negro
Black
Negro
Nero
Noir



Accesorio opcional:
Tapón salida de humos para instalación trasera.
Véase pág. 115



Puerta y rejilla en fundición
Tubo de salida de humos (no incluido)

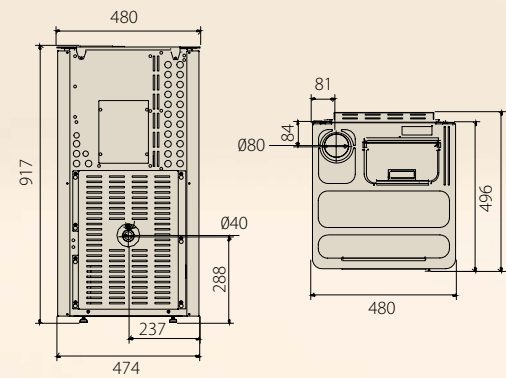

Blanco perla
White pearl
Branco pérola
Bianco perla
Perle blanche

Rojo imperial
Imperial red
Bermelho imperial
Rosso imperiale
Rouge impériale

Negro
Black
Negro
Nero
Noir



OPCIONAL



OPCIONAL



GÉNESIS GLASS

10 Kw | 12 Kw

A+

Kw Total	11,3 Kw 11,2 Kw	Min-Max	96 - 91 % 96 - 89 %	Min-Max	40 - 9 h 40 - 8 h	40 mm
Kw Nominal	10,1 Kw 11,1 Kw	Kg	120 Kg	Kg/h	0,5 - 2,3 0,5 - 2,5	245 m³ 325 m³
Kw Min-Max	2,4 - 10,1 Kw 2,4 - 11,1 Kw	Kg	20 Kg	mm	897 x 295 x 1086	80 mm

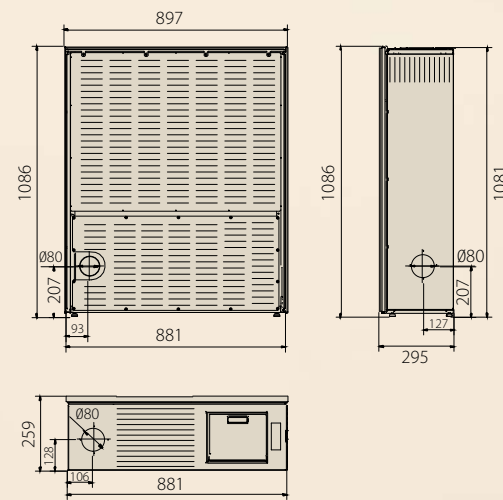

Puerta y frontal en cristal serigrafiado



POSIBLES CONEXIONES DE SALIDA DE HUMOS

- A. Salida superior
- B. Salida trasera
- C. Salida lateral derecho



GÉNESIS STEEL

10 Kw | 12 Kw

A+

Kw Total	11,3 Kw 11,2 Kw	Min-Max	96 - 91 % 96 - 89 %	Min-Max	40 - 9 h 40 - 8 h	40 mm
Kw Nominal	10,1 Kw 11,1 Kw	Kg	120 Kg	Kg/h	0,5 - 2,3 0,5 - 2,5	245 m³ 325 m³
Kw Min-Max	2,4 - 10,1 Kw 2,4 - 11,1 Kw	Kg	20 Kg	mm	897 x 295 x 1086	80 mm

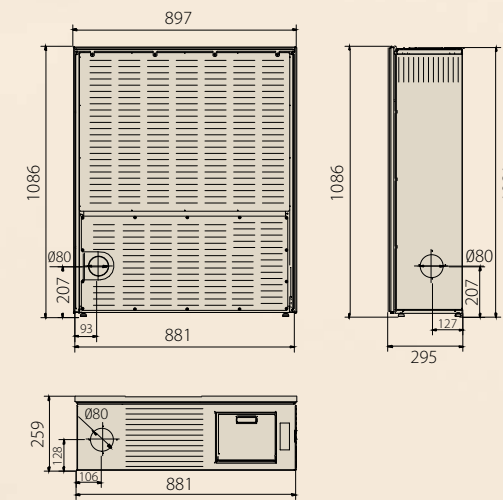

Puerta en cristal serigrafiado



- Blanco perla**
White pearl
Branco pérola
Bianco perla
Perle blanche
- Rojo imperial**
Imperial red
Bermelho imperial
Rosso imperiale
Rouge impériale
- Negro**
Black
Negro
Nero
Noir
- Marrón vintage**
Vintage brown
Marron vintage
Marrone vintage
Marron vintage

POSIBLES CONEXIONES DE SALIDA DE HUMOS

- A. Salida superior
- B. Salida trasera
- C. Salida lateral derecho

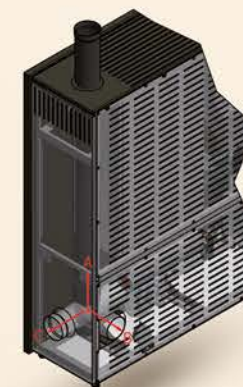

IRIS

12 Kw | 15 Kw

A+

Kw Total	14 Kw 16,6 Kw	Kg	136 Kg	mm	524 x 540 x 1122
Kw Nominal	12,5 Kw 14,7 Kw	Kg	30 Kg	mm	60 mm
Kw Min-Max	4,6 - 12,5 Kw 4,6 - 14,7 Kw	Min-Max	30 - 10 h 30 - 9 h	m³	325 m³ 375 m³
Min-Max	92 - 88 % 92 - 87 %	Kg/h Min-Max	1 - 2,9 1 - 3,4	mm	80 mm



NEREA

12 Kw | 15 Kw

A+

Kw Total	14 Kw 16,6 Kw	Kg	132 Kg	mm	514 x 541 x 1104
Kw Nominal	12,5 Kw 14,7 Kw	Kg	30 Kg	mm	60 mm
Kw Min-Max	4,6 - 12,5 Kw 4,6 - 14,7 Kw	Min-Max	30 - 10 h 30 - 9 h	m³	325 m³ 375 m³
Min-Max	92 - 88 % 92 - 87 %	Kg/h Min-Max	1 - 2,9 1 - 3,4	mm	80 mm



Puerta en cristal serigrafiado

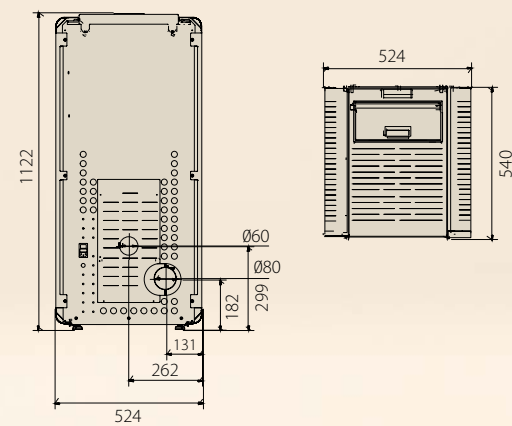

Blanco perla
White pearl
Branco pérola
Bianco perla
Perle blanche

Rojo imperial
Imperial red
Bermelho imperial
Rosso imperiale
Rouge impériale

Negro
Black
Nero
Noir

Marrón vintage
Vintage brown
Marrom vintage
Marrone vintage
Marron vintage



Puerta y rejilla en fundición

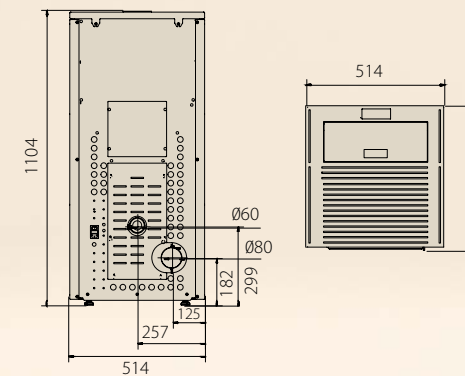

Blanco perla
White pearl
Branco pérola
Bianco perla
Perle blanche

Rojo imperial
Imperial red
Bermelho imperial
Rosso imperiale
Rouge impériale

Negro
Black
Nero
Noir

Marrón vintage
Vintage brown
Marrom vintage
Marrone vintage
Marron vintage



OPCIONAL



OPCIONAL



ESTELA

12 Kw | 15 Kw

A+

Kw Total	14 Kw 16,6 Kw	92 - 88 % Min-Max 92 - 87 %	30 - 10 h Min-Max 30 - 9 h	60 mm
Kw Nominal	12,5 Kw 14,7 Kw	132 Kg	Kg/h 1 - 2,9 Min-Max 1 - 3,4	325 m³ 375 m³
Kw Min-Max	4,6 - 12,5 Kw 4,6 - 14,7 Kw	30 Kg	520 x 542 x 1104 mm	80 mm



FERLUX.ES

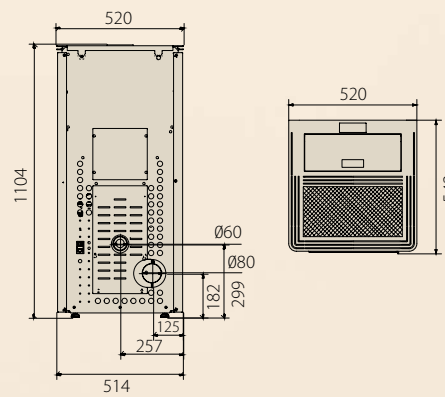

Puerta y rejilla en fundición



Blanco perla
White pearl
Branco pérola
Bianco perla
Perle blanche

Rojo imperial
Imperial red
Bermelho imperial
Rosso imperiale
Rouge impériale

Marrón vintage
Vintage brown
Marrom vintage
Marrone vintage
Marron vintage



ULYSES INSERTABLE

8 Kw | 10 Kw

A+

Kw Total	9,3 Kw 11,2 Kw	94 - 90 % Min-Max 94 - 88 %	19 - 7 h Min-Max 19 - 6 h	40 mm
Kw Nominal	8,5 Kw 10,2 Kw	99 Kg	Kg/h Min-Max 0,7 - 1,9 0,7 - 2,3	195 m ³ 245 m ³
Kw Min-Max	3,4 - 8,5 Kw 3,4 - 10,2 Kw	13 Kg	640 x 556 x 579 mm	80 mm



FERLUX . E S

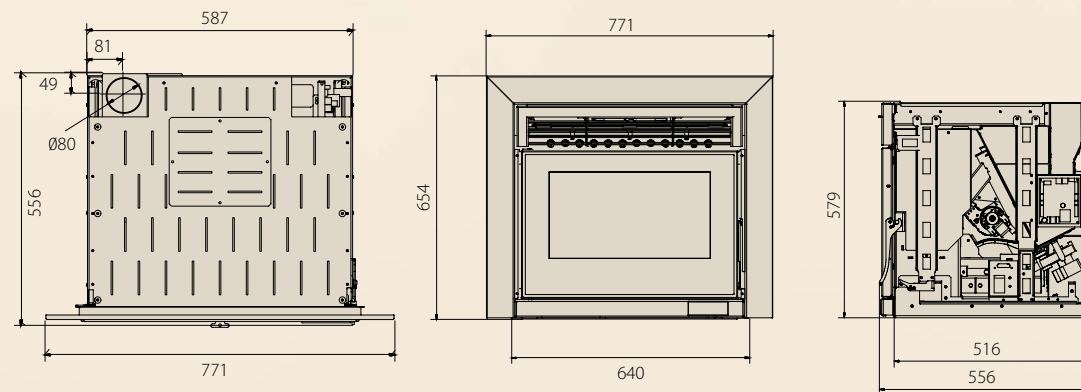

Medidas con marco
Measures with frame
Medidas com quadro
Misure con cornice
Mesures avec cadre



Puerta en cristal serigrafiado

ACCESORIOS PARA INSERTABLE

Véase pág. 114

Base de apoyo con altura regulable.

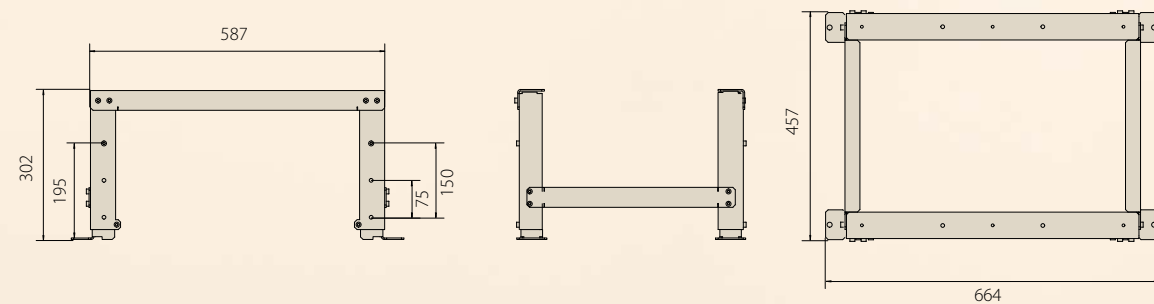

ACCESORIOS INSERTABLE

Véase pág. 114

Tubo adicional de llenado telescópico, con posibilidad de instalación derecha o izquierda.

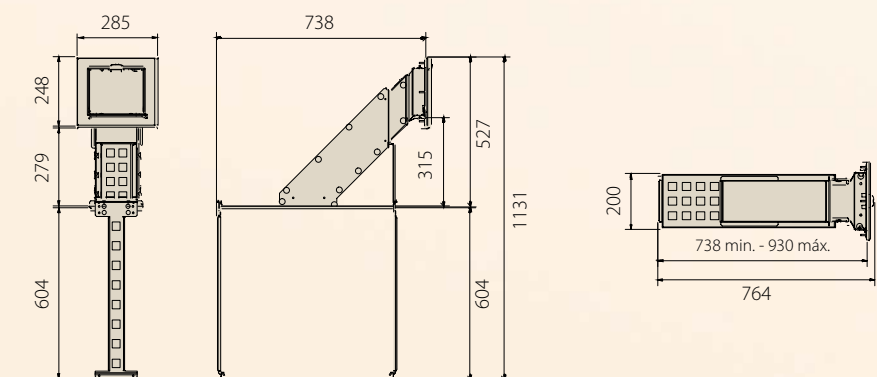

OPCIONAL





GAMA CANALIZABLE

Una sola estufa para calentar varios ambientes a través de canalizaciones. Permite gestionar de manera independiente la temperatura y el flujo de aire donde se encuentra instalado el aparato respecto a las habitaciones contiguas, incluso en plantas diferentes de la casa.

- OSIRIS
- NORA
- LYRA
- ÍKARO
- PHOENIX GLASS
- PHOENIX STEEL

GAMA CANALIZABLE

ESQUEMAS TÉCNICOS

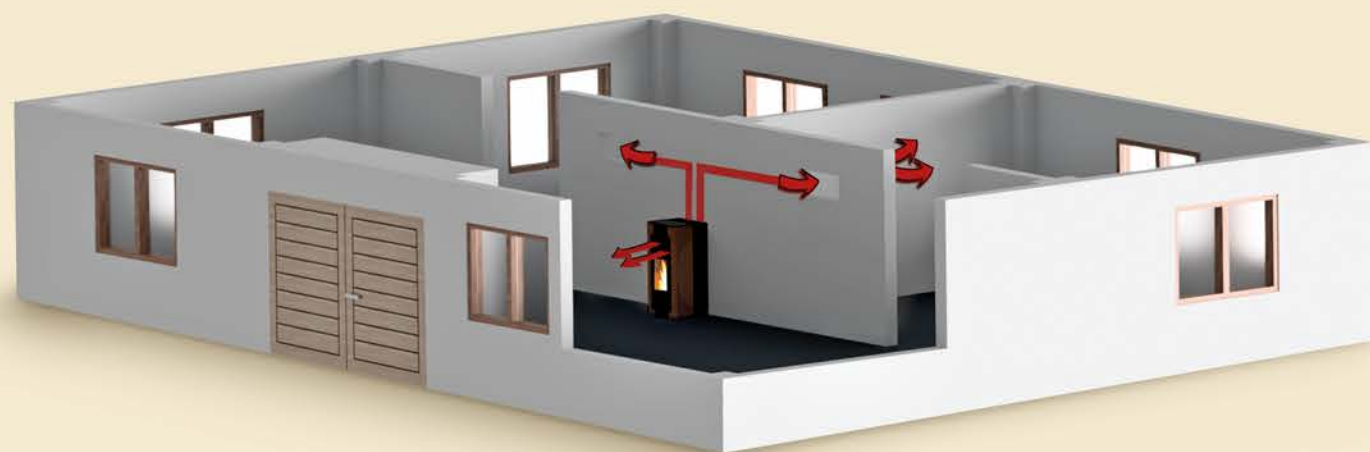

LYRA · NORA

2 Canalizaciones

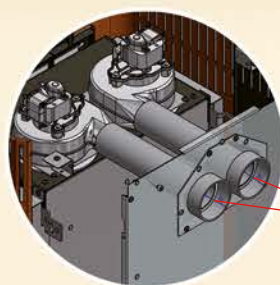
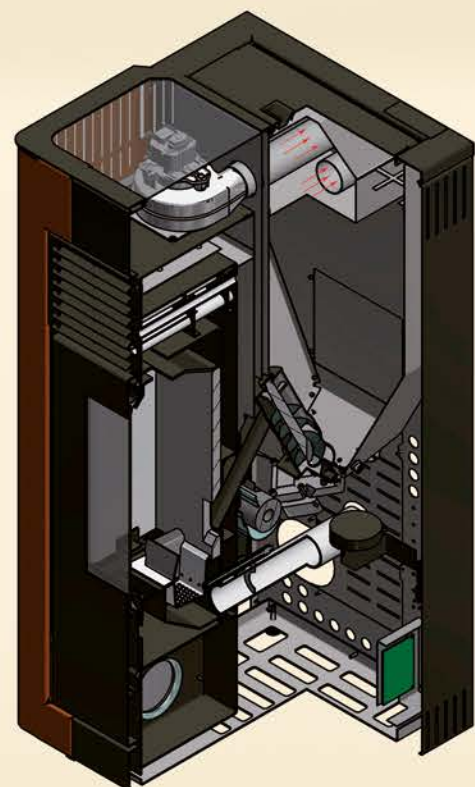

Salidas de canalización

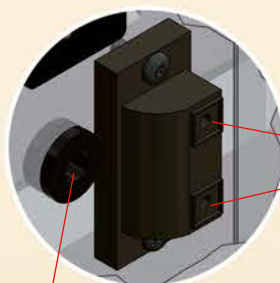

Conexión sonda segunda estancia

Sonda estancia principal

OSIRIS

1 Canalización

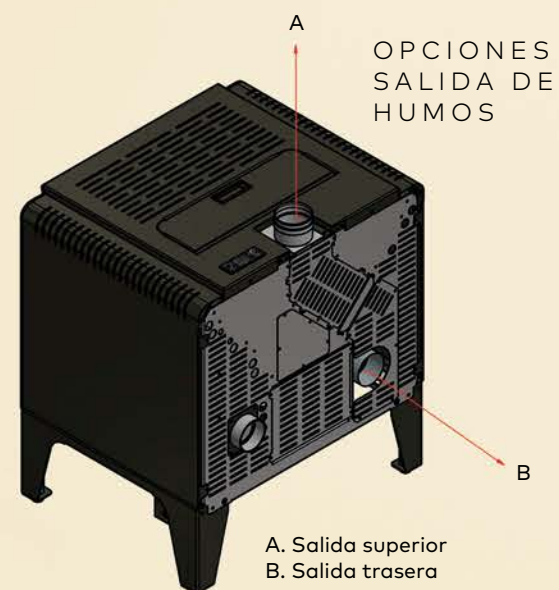

ÍKARO

1 Canalización

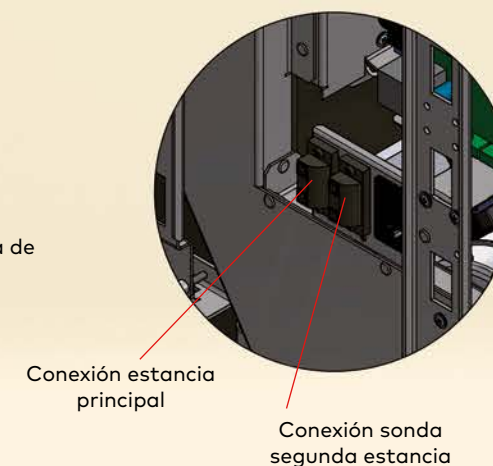
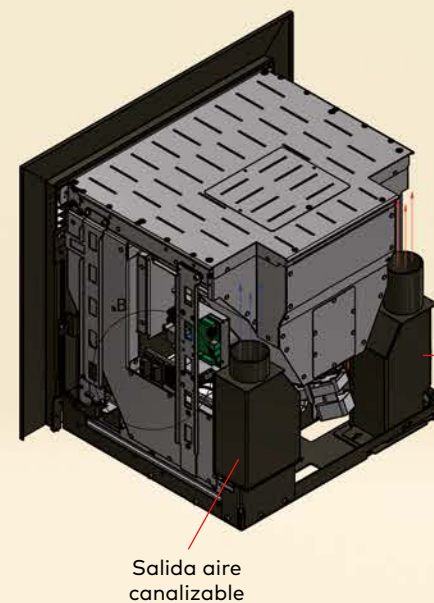

PHOENIX

1 Canalización

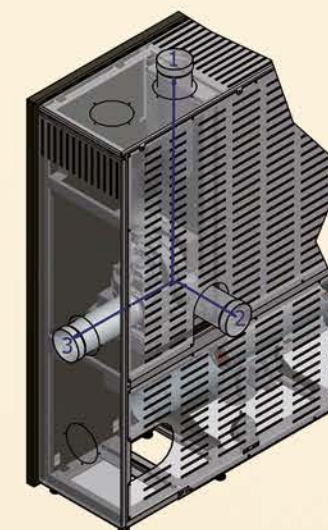
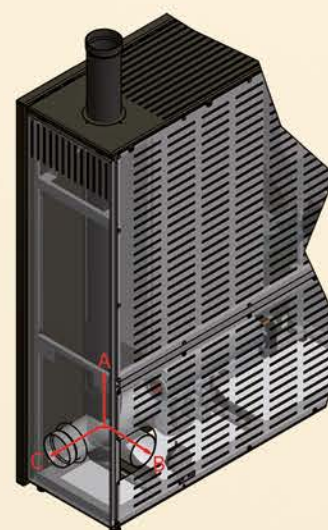

OSIRIS CANALIZABLE

8 Kw | 10 Kw

A+

Kw Total	9,3 Kw 11,2 Kw	Min-Max	94 - 90 % 94 - 88%	Min-Max	30 - 11 h 30 - 9 h	40 mm
Kw Nominal	8,5 Kw 10,2 Kw	Kg	122 Kg	Kg/h Min-Max	0,7 - 1,9 0,7 - 2,3	195 m ³ 245 m ³
Kw Min-Max	3,4 - 8,5 Kw 3,4 - 10,2 Kw	Kg	21 Kg	mm	700 x 571 x 805	80 mm

1 canalización



NORA CANALIZABLE

8 Kw | 10 Kw

A+

Kw Total	9,3 Kw 10,8 Kw	Min-Max	94 - 88 % 94 - 88%	Min-Max	37 - 12 h 37 - 10 h	40 mm
Kw Nominal	8,2 Kw 9,5 Kw	Kg	130 Kg	Kg/h Min-Max	0,6 - 1,9 0,6 - 2,2	195 m ³ 245 m ³
Kw Min-Max	2,8 - 8,2 Kw 2,8 - 9,5 Kw	Kg	22 Kg	mm	478 x 499 x 1097	80 mm

2 canalizaciones



FERLUX . E S



- | | | | |
|--|---|--|---|
| Blanco perla
White pearl
Branco pérola
Bianco perla
Perle blanche | Rojo imperial
Imperial red
Bermelho imperial
Rosso imperiale
Rouge impériale | Negro
Black
Negro
Nero
Noir | Marrón vintage
Vintage brown
Marron vintage
Marrone vintage
Marron vintage |
|--|---|--|---|

Puerta en cristal serigrafiado

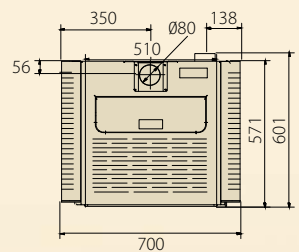
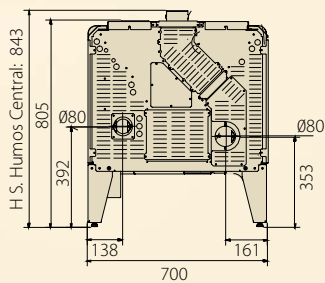

Accesorio opcional:
Salida de humo vertical
MODELO B
Véase pág. 114

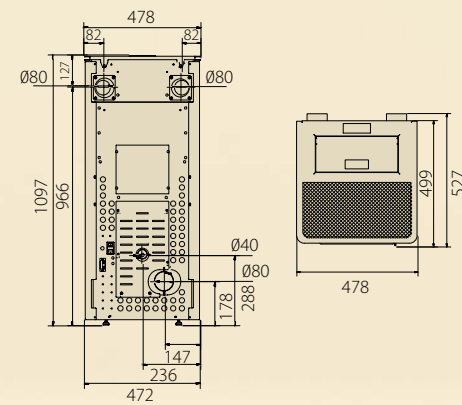

Puerta y rejilla en fundición



- | | | | |
|--|---|--|---|
| Blanco perla
White pearl
Branco pérola
Bianco perla
Perle blanche | Rojo imperial
Imperial red
Bermelho imperial
Rosso imperiale
Rouge impériale | Negro
Black
Negro
Nero
Noir | Marrón vintage
Vintage brown
Marron vintage
Marrone vintage
Marron vintage |
|--|---|--|---|

OPCIONAL



OPCIONAL



CANALIZABLE



LYRA CANALIZABLE

12 Kw | 15 Kw

A+

Kw Total	14 Kw 16,6 Kw	Min-Max	92 - 88 % 92 - 87 %	Min-Max	29 - 10 h 29 - 9 h		40 mm
Kw Nominal	12,5 Kw 14,7 Kw	Kg	160 Kg	Kg/h Min-Max	1 - 2,9 1 - 3,4		325 m ³ 375 m ³
Kw Min-Max	4,6 - 12,5 Kw 4,6 - 14,7 Kw	Kg	29 Kg	mm	561 x 542 x 1190		80 mm

2 canalizaciones



Accesorio opcional:
Convoyador para pasar de dos a una canalización.
Véase pág. 115

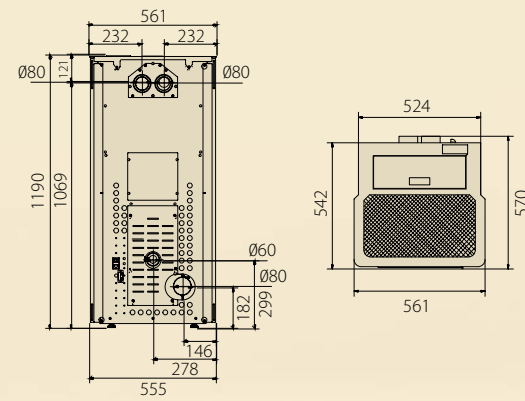
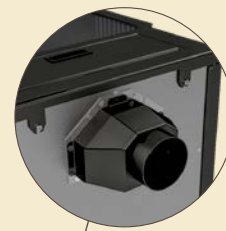

Blanco perla White pearl Bianco pérola Bianco perla Perle blanche	Rojo imperial Imperial red Bermelho imperial Rosso imperiale Rouge impériale	Marrón vintage Marrom vintage Vintage brown Marrone vintage Marron vintage	Negro Black Negro Nero Noir
--	---	---	--



Puerta y rejilla en fundición

OPCIONAL



ÍKARO CANALIZABLE

8 Kw | 10 Kw

A+

Kw Total	9,3 Kw 11,2 Kw	Min-Max	94 - 90 % 94 - 88 %	Min-Max	19 - 7 h 19 - 6 h		40 mm
Kw Nominal	8,5 Kw 10,2 Kw	Kg	105 Kg	Kg/h Min-Max	0,7 - 1,9 0,7 - 2,3		195 m ³ 245 m ³
Kw Min-Max	3,4 - 8,5 Kw 3,4 - 10,2 Kw	Kg	15 Kg	mm	640 x 577 x 611		80 mm

1 canalización

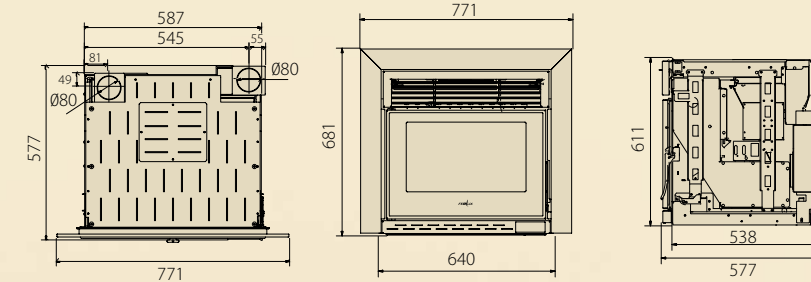

Puerta en cristal serigrafado

ACCESORIOS INSERTABLE

Véase pág. 114

Tubo adicional de llenado telescópico, con posibilidad de instalación derecha o izquierda.

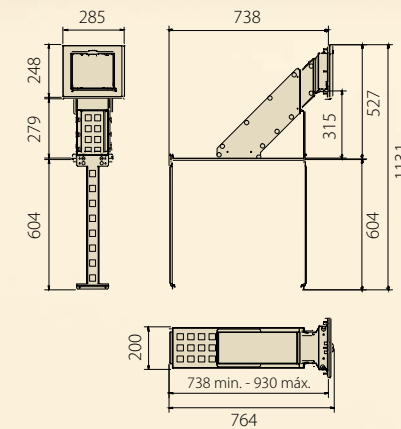

Base de apoyo con altura regulable

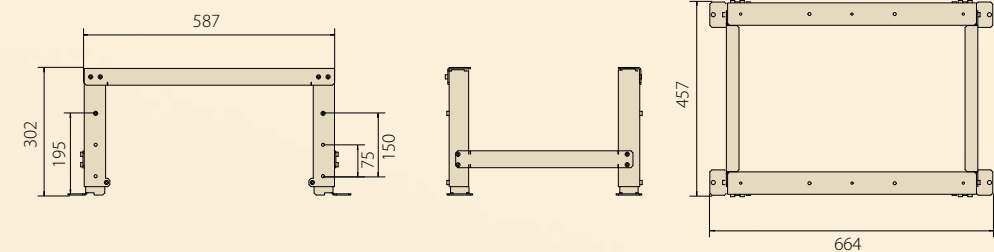

OPCIONAL



PHOENIX GLASS CANALIZABLE

10 Kw | 12 Kw

A+

Kw Total	11,3 Kw 12,2 Kw	Min-Max	96 - 91 % 96 - 89 %	Min-Max	40 - 9 h 40 - 8 h	mm	40 mm	1 canalización
Kw Nominal	10,1 Kw 11,1 Kw	Kg	130 Kg	Kg/h	0,5 - 2,3 Min-Max 0,6 - 2,5	m³	245 m³ 325 m³	
Kw Min-Max	2,4 - 10,1 Kw 2,4 - 11,1 Kw	Kg	20 Kg	mm	1070 x 295 x 1086	mm	80 mm	

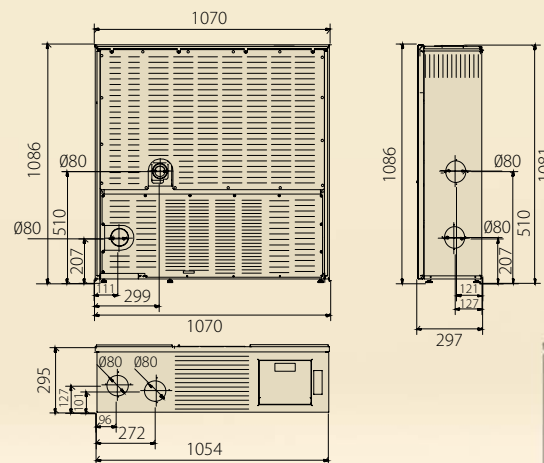

Puerta y frontal en cristal serigrafiado



PHOENIX STEEL CANALIZABLE

10 Kw | 12 Kw

A+

Kw Total	11,3 Kw 12,2 Kw	Min-Max	96 - 91 % 96 - 89 %	Min-Max	40 - 9 h 40 - 8 h	mm	40 mm	1 canalización
Kw Nominal	10,1 Kw 11,1 Kw	Kg	130 Kg	Kg/h	0,5 - 2,3 Min-Max 0,6 - 2,5	m³	245 m³ 325 m³	
Kw Min-Max	2,4 - 10,1 Kw 2,4 - 11,1 Kw	Kg	20 Kg	mm	1070 x 295 x 1086	mm	80 mm	

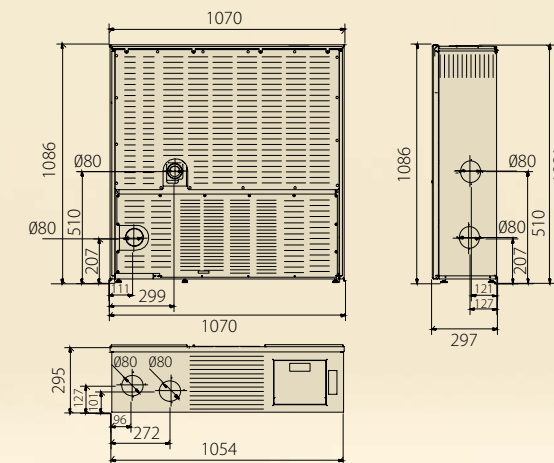

Puerta en cristal serigrafiado



- Blanco perla**
White pearl
Bianco pérola
Bianco perla
Perle blanche
- Rojo imperial**
Imperial red
Bermelho imperial
Rosso imperiale
Rouge impériale
- Negro**
Black
Negro
Nero
Noir
- Marrón vintage**
Vintage brown
Marron vintage
Marrone vintage
Marron vintage



G A M A A G U A

Diseñadas para integrarse en cualquier ambiente, garantizando un confort en toda la casa. Las hidroestufas permiten calentar la vivienda de forma uniforme a través de una instalación hidráulica mediante radiadores o suelo radiante.

- IRIS HIDRO
- LUNA HIDRO
- SELENA
- ALTEA



ESQUEMA DE INSTALACIÓN SIMPLIFICADO



COTAS PARTE TRASERA

Iris 15 | 18

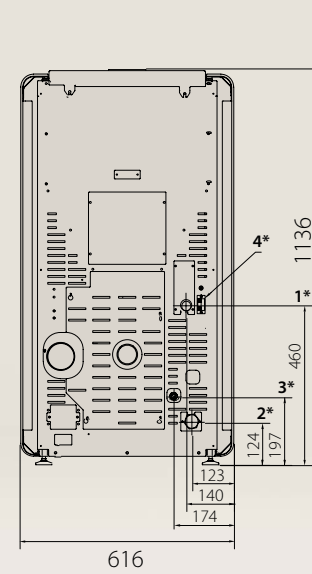

Luna 15 | 18

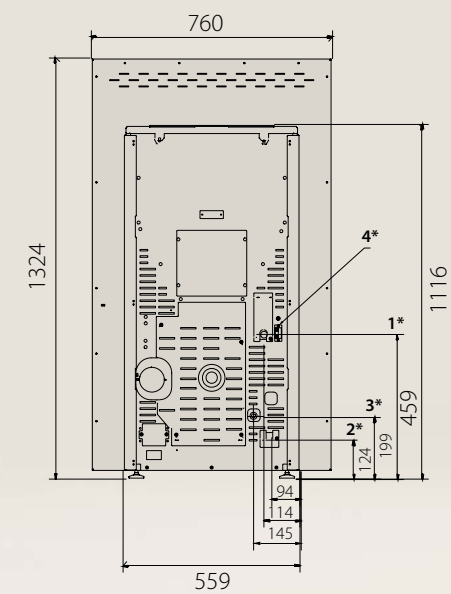

Altea - Selena 15 | 18

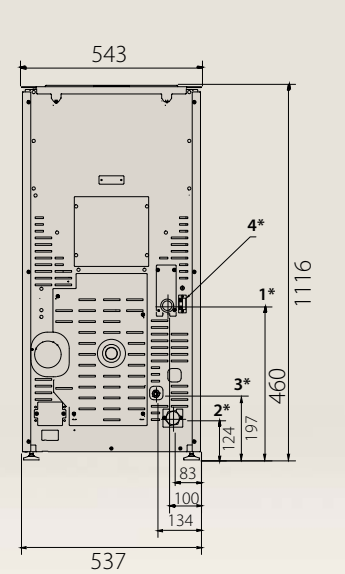

Iris 27

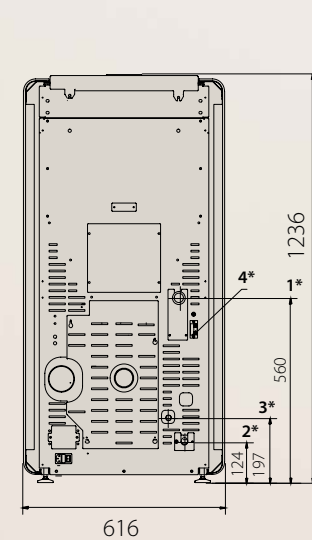

Luna 27

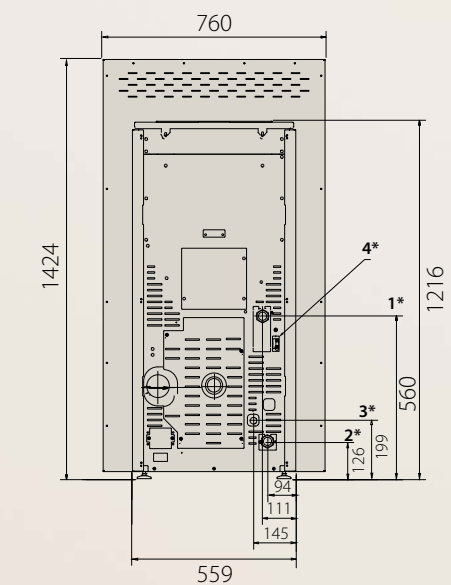

Altea - Selena 27

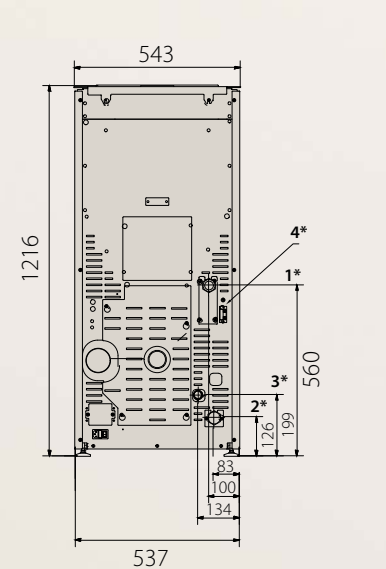

- 1* Ida
- 2* Retorno
- 3* Válvula de seguridad
- 4* Termostato ambiente

Limpieza manual del paso de humos

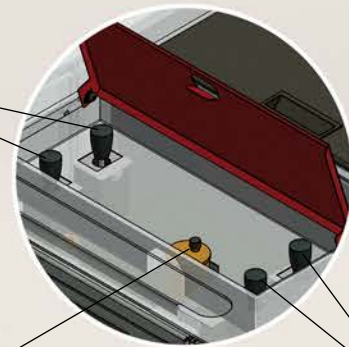

Purgador automático

Limpieza manual del paso de humos

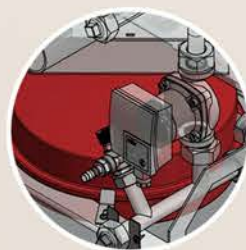
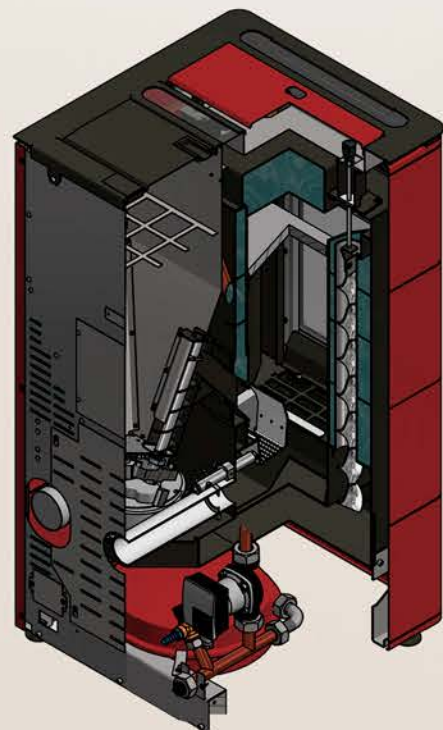

Vaso de expansión de 8 o 12 litros



Válvula de seguridad de 3 bar y transductor de presión

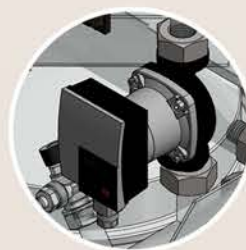

Bomba de circulación electrónica

IRISHIDRO

1 5 | 1 8

A++

Kw Total	17,8 Kw 21,2 Kw	Min-Max	96 - 95 % 96 - 94 %	Min-Max	32 - 10 h 32 - 8,3 h	mm	60 mm
Kw Min-Max	5,3 - 16,7 Kw 5,3 - 19,8 Kw	Kg	178 Kg	Kg/h Min-Max	1,1 - 3,6 kg 1,1 - 4,2 kg	m³	250 m ³ 375 m ³
Kw Min-Max	3,6 - 13,6 Kw 3,6 - 16,2 Kw	Kg	35 Kg	mm	616 x 605 x 1136	mm	80 mm



IRISHIDRO

2 7

A++

Kw Total	27,9 Kw	Min-Max	95 - 93 %	Min-Max	32 - 8 h	mm	60 mm
Kw Min-Max	6,8 - 25,8 Kw	Kg	225 Kg	Kg/h Min-Max	1,4 - 5,6 Kg	m³	690 m ³
Kw Min-Max	5,1 - 21,6 Kw	Kg	45 Kg	mm	616 x 605 x 1236	mm	80 mm



FERLUX . ES

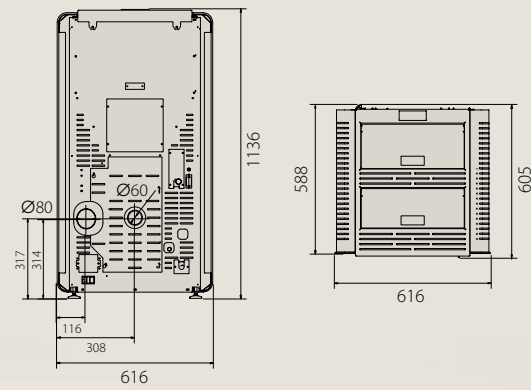

Puerta en cristal serigrafiado



- Blanco perla**
White pearl
Bianco pérola
Bianco perla
Perle blanche
- Rojo imperial**
Imperial red
Bermelho imperial
Rosso imperiale
Rouge impériale
- Negro**
Black
Negro
Nero
Noir
- Marrón vintage**
Vintage brown
Marron vintage
Marrone vintage
Marron vintage

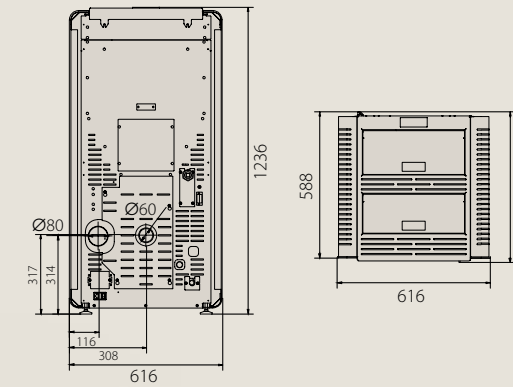

Puerta en cristal serigrafiado



- Blanco perla**
White pearl
Bianco pérola
Bianco perla
Perle blanche
- Rojo imperial**
Imperial red
Bermelho imperial
Rosso imperiale
Rouge impériale
- Negro**
Black
Negro
Nero
Noir
- Marrón vintage**
Vintage brown
Marron vintage
Marrone vintage
Marron vintage

OPCIONAL



OPCIONAL



AGUA

LUNA HIDRO

15 | 18

A++

Kw Total	17,8 Kw 21,2 Kw	Kg	182 Kg	mm	760 x 600 x 1324
Kw Min-Max	5,3 - 16,7 Kw 5,3 - 19,8 Kw	Kg	35 Kg	mm	60 mm
Kw Min-Max	3,6 - 13,6 Kw 3,6 - 16,2 Kw	h	32 - 10 h 32 - 8,3 h	m³	250 m ³ 375 m ³
Min-Max	96 - 95 % 96 - 94 %	Kg/h	1,1 - 3,6 Kg 1,1 - 4,2 Kg	mm	80 mm



Puerta en cristal serigrafiado

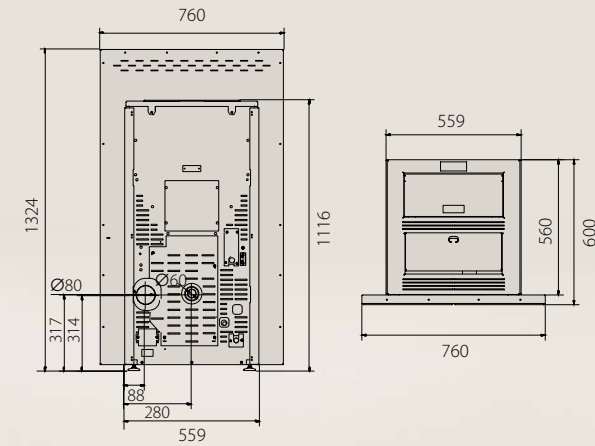

Blanco perla White pearl Branco pérola Bianco perla Perle blanche	Marrón vintage Vintage brown Marron vintage Marrone vintage Marron vintage	Glass Glass Glass Glass Glass
--	---	--

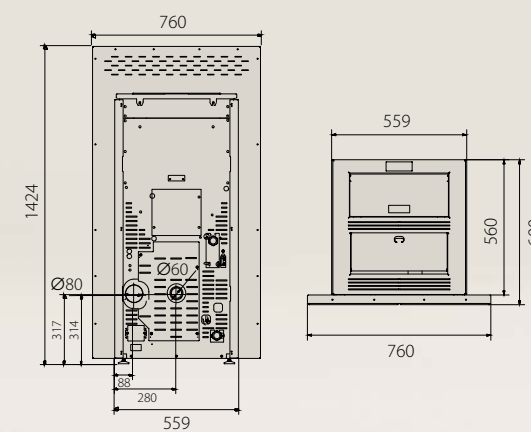

Blanco perla White pearl Branco pérola Bianco perla Perle blanche	Marrón vintage Vintage brown Marron vintage Marrone vintage Marron vintage	Glass Glass Glass Glass Glass
--	---	--

LUNA HIDRO

27

A++

Kw Total	27,9 Kw	Kg	231 Kg	mm	760 x 600 x 1424
Kw Min-Max	6,8 - 25,8 Kw	Kg	45 Kg	mm	60 mm
Kw Min-Max	5,1 - 21,6 Kw	h	32 - 8 h	m³	690 m ³
Min-Max	95 - 93 %	Kg/h	1,4 - 5,6 kg	mm	80 mm

Puerta en cristal serigrafiado



OPCIONAL

OPCIONAL



SELENA

15 | 18

A++

Kw Total	17,8 Kw 21,2 Kw	Min-Max	96 - 95 % 96 - 94 %	Min-Max	32 - 10 h 32 - 8,3 h	mm	60 mm
Kw Min-Max	5,3 - 16,7 Kw 5,3 - 19,8 Kw	Kg	170 Kg	Kg/h Min-Max	1,1 - 3,6 Kg 1,1 - 4,2 Kg	m³	250 m³ 375 m³
Kw Min-Max	3,6 - 13,6 Kw 3,6 - 16,2 Kw	Kg	35 Kg	mm	543 x 605 x 1116	mm	80 mm



SELENA

27

A++

Kw Total	27,9 Kw	Min-Max	95 - 93 %	Min-Max	32 - 8 h	mm	60 mm
Kw Min-Max	6,8 - 25,8 Kw	Kg	218 Kg	Kg/h Min-Max	1,4 - 5,6 Kg	m³	690 m³
Kw Min-Max	5,1 - 21,6 Kw	Kg	45 Kg	mm	543 x 605 x 1216	mm	80 mm



FERLUX . E S

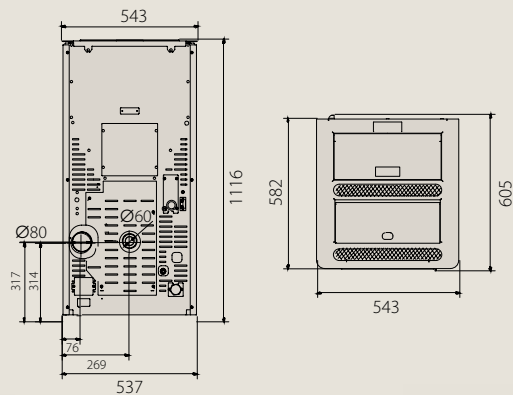

Puerta y rejilla en fundición



- Blanco perla**
White pearl
Bianco pérola
Bianco perla
Perle blanche
- Rojo imperial**
Imperial red
Bermelho imperial
Rosso imperiale
Rouge impériale
- Negro**
Black
Negro
Nero
Noir
- Marrón vintage**
Vintage brown
Marron vintage
Marrone vintage
Marron vintage

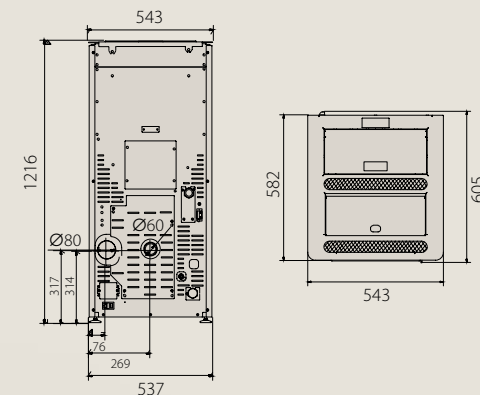

Puerta y rejilla en fundición



- Blanco perla**
White pearl
Bianco pérola
Bianco perla
Perle blanche
- Rojo imperial**
Imperial red
Bermelho imperial
Rosso imperiale
Rouge impériale
- Negro**
Black
Negro
Nero
Noir
- Marrón vintage**
Vintage brown
Marron vintage
Marrone vintage
Marron vintage

OPCIONAL



OPCIONAL



AGUA

ALTEA

1 5 | 1 8

A++

Kw Total	17,8 Kw 21,2 Kw	Min-Max	96 - 95% 96 - 94%	Min-Max	32 - 10h 32 - 8,3h	mm	60 mm
Kw Min-Max	5,3 - 16,7 Kw 5,3 - 19,8 Kw	Kg	170 Kg	Kg/h Min-Max	1,1 - 3,6 kg 1,1 - 4,2 kg	m³	250 m ³ 375 m ³
Kw Min-Max	3,6 - 13,6 Kw 3,6 - 16,2 Kw	Kg	35 Kg	mm	543 x 605 x 1116	mm	80 mm



ALTEA

2 7

A++

Kw Total	27,9 Kw	Min-Max	95 - 93 %	Min-Max	32 - 8 h	mm	60 mm
Kw Min-Max	6,8 - 25,8 Kw	Kg	218 Kg	Kg/h Min-Max	1,4 - 5,6 Kg	m³	690 m ³
Kw Min-Max	5,1 - 21,6 Kw	Kg	45 Kg	mm	543 x 605 x 1216	mm	80 mm



FERLUX . E S

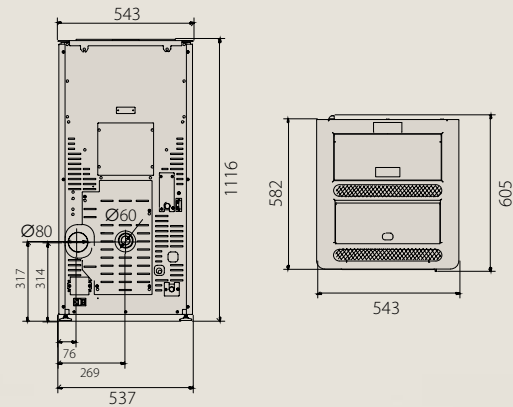

Puerta y rejilla en fundición



- | | | | |
|--|---|--|---|
| Blanco perla
White pearl
Branco pérola
Bianco perla
Perle blanche | Rojo imperial
Imperial red
Bermelho imperial
Rosso imperiale
Rouge impériale | Negro
Black
Negro
Nero
Noir | Marrón vintage
Vintage brown
Marron vintage
Marrone vintage
Marron vintage |
|--|---|--|---|

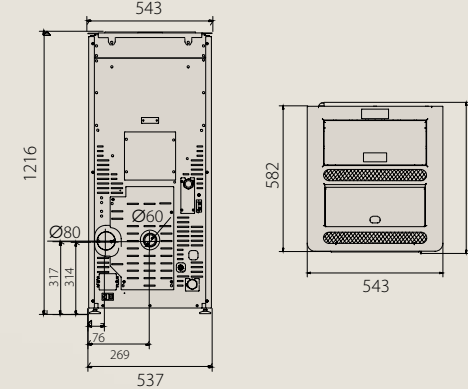

Puerta y rejilla en fundición



- | | | | |
|--|---|--|---|
| Blanco perla
White pearl
Branco pérola
Bianco perla
Perle blanche | Rojo imperial
Imperial red
Bermelho imperial
Rosso imperiale
Rouge impériale | Negro
Black
Negro
Nero
Noir | Marrón vintage
Vintage brown
Marron vintage
Marrone vintage
Marron vintage |
|--|---|--|---|

OPCIONAL



OPCIONAL





GAMACALDERAS

Pensadas para instalarse en pequeños hábitáculos gracias a sus dimensiones reducidas. Fabricadas con los mejores componentes y la última tecnología avanzada, para garantizar el máximo confort a nuestros clientes.

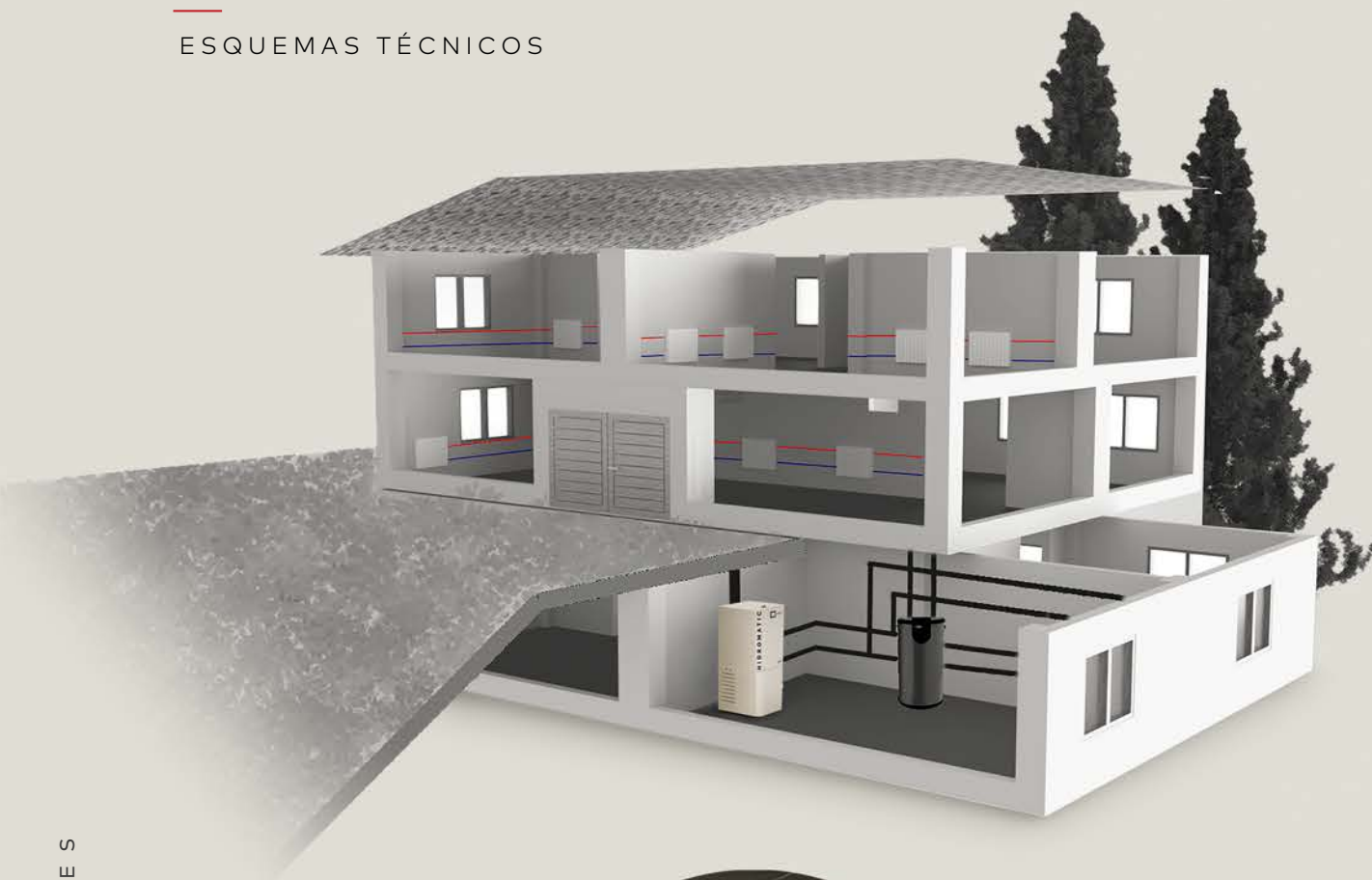

ESQUEMA DE INSTALACIÓN SIMPLIFICADO

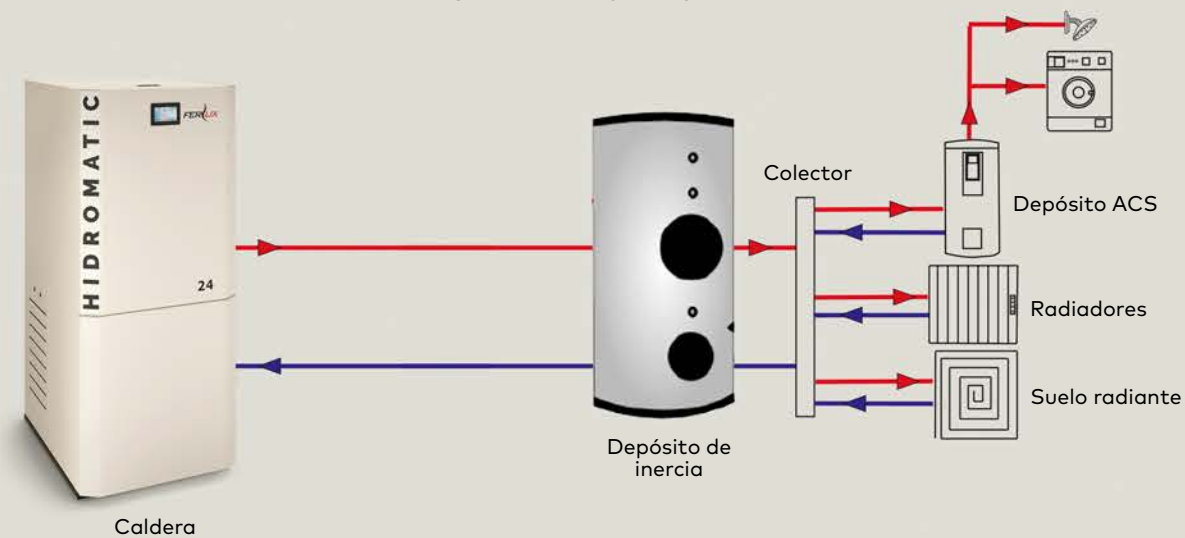

FERLUX.ES

CALDERAS



Detalle 4 pasos de humos.

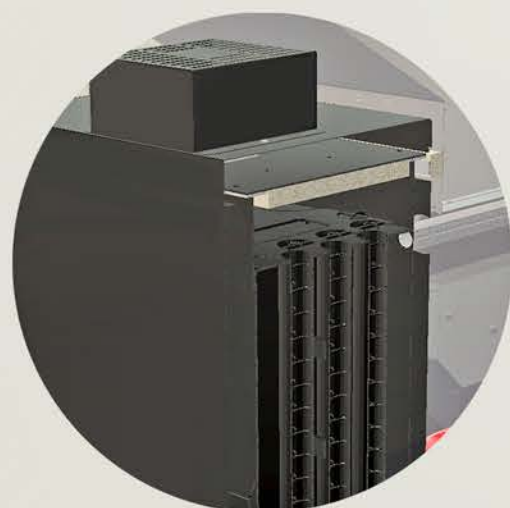

Detalle limpieza paso de humos.



Detalle braseiro.

COTAS PARTE TRASERA

Hidromatic 12 - 18

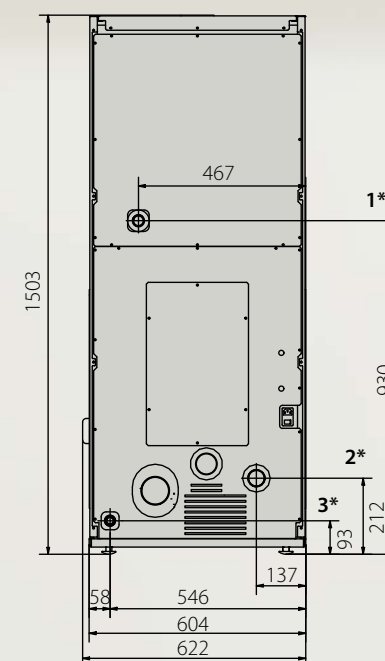

Hidromatic 24 - 30 - 35

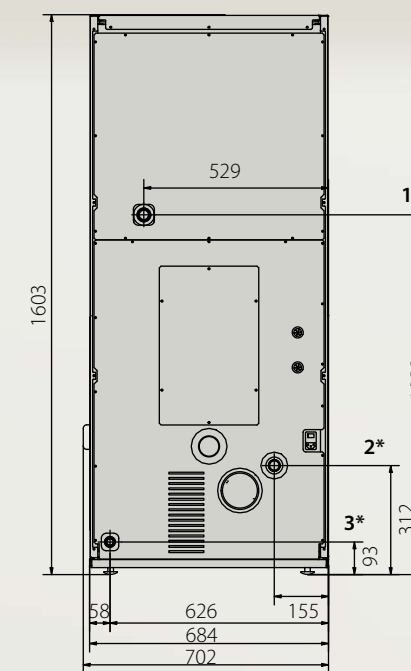

- 1* Ida
- 2* Retorno
- 3* Válvula de seguridad

HIDROMATIC

1 2 | 1 8

A++

Kw Min-Max	3,62 - 12,14 Kw 5,86 - 18,26 Kw	Min-Max	96 - 95 % 96 - 95 %	Min-Max	129 - 33 h 82 - 23 h	mm	60 mm
Kw	12 Kw 18 Kw	Kg	320 Kg	Kg/h Min-Max	0,7 - 2,7 Kg 1,1 - 4,0 Kg	m³	250 m ³ 350 m ³
Kg	90 Kg aprox.	mm	80 mm Aumento obligatorio de 80-100mm	mm	622 x 837 x 1503		



HIDROMATIC

2 4 | 3 0 | 3 5

A++

Kw Min-Max	7,97 - 24,11 Kw 9,16 - 31,29 Kw 10,76 - 35,58 Kw	Min-Max	95 - 94 % 97 - 94 % 96 - 93 %	Min-Max	69 - 19 h 54 - 15 h 47 - 13 h	mm	60 mm
Kw	24 Kw 30 Kw 35 Kw	Kg	360 Kg	Kg/h Min-Max	1,5 - 5,4 Kg 1,9 - 6,8 Kg 2,2 - 8,0 Kg	m³	500 m ³ 600 m ³ 700 m ³
Kg	103 Kg aprox.	mm	100 mm Aumento obligatorio de 100-120mm	mm	702 x 837 x 1603		



FERLUX . E S

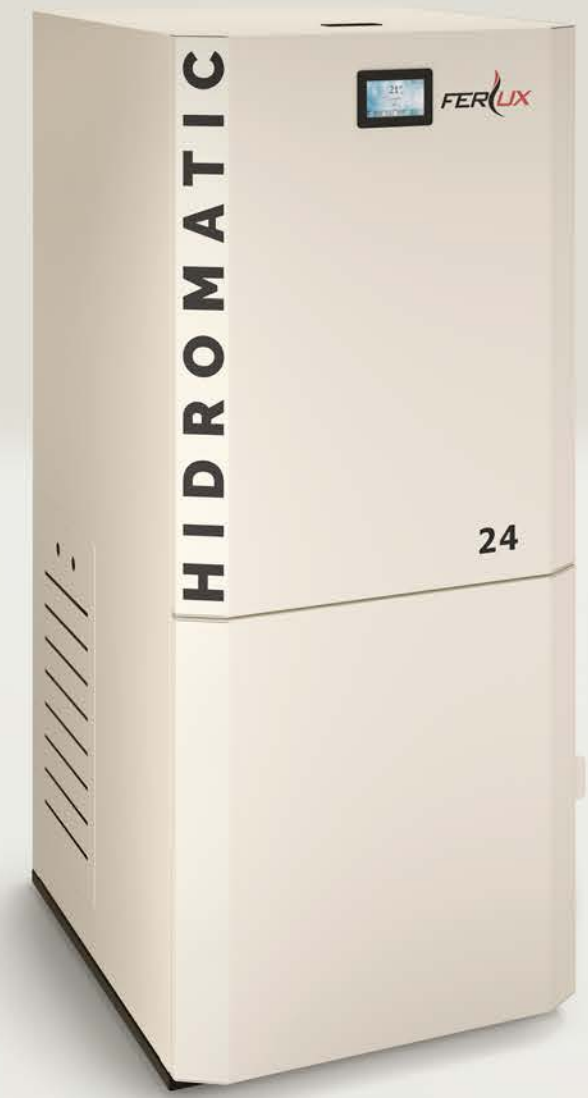
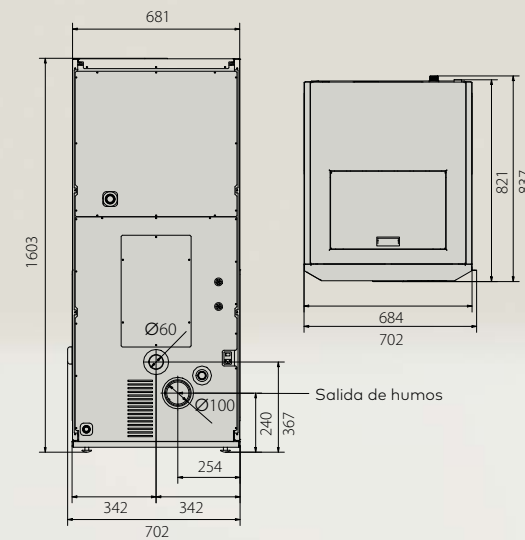
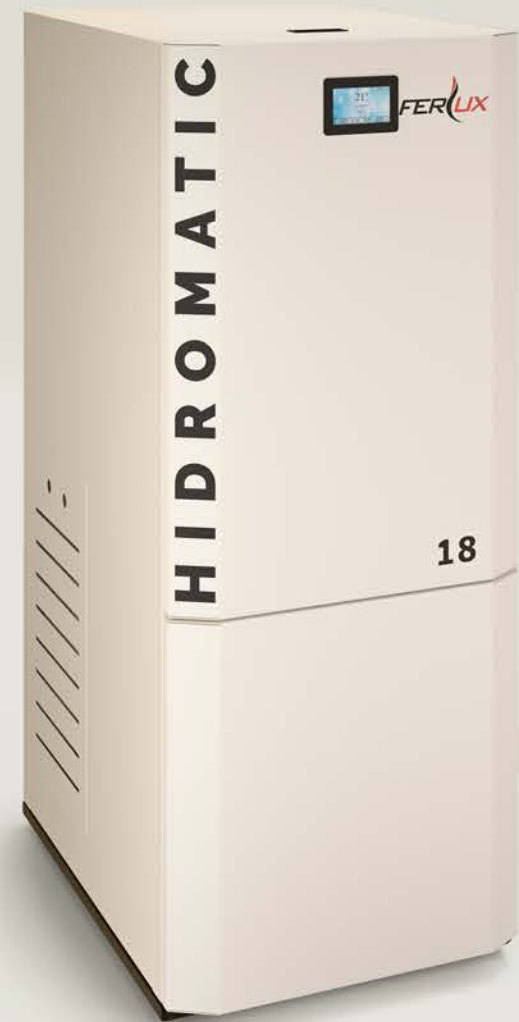
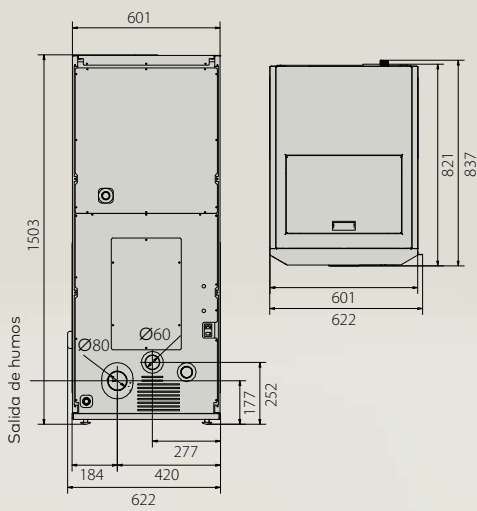

⚠ Obligatorio uso válvula anticondensación a 55° C. No incluida.

⚠ Obligatorio uso válvula anticondensación a 55° C. No incluida.



OPCIONAL



OPCIONAL



GAMALEÑA



- INSERTABLES
- TERMOCHIMENEAS
- ESTUFAS
- HORNOS
- BARBACOAS



GAMAINERTABLES

Con una variedad de productos respecto a la potencia, dimensiones y diseños que se adaptan fácilmente en cualquier ambiente. Pensados para dar el máximo confort y bienestar gracias al sistema de turbinas silenciosas.

- GALAXY
- TAURUS
- GALAXY MINIMAL
- GALAXY LEÑERO
- GALAXY MUEBLE
- PANORAMIC 700 1C
- PANORAMIC 700 2C
- PANORAMIC 700 3C
- PANORAMIC 900 1C
- PANORAMIC 900 2C
- PANORAMIC 900 3C
- IMAZ
- 753
- 755
- 760 SERIGRAFIADO
- 860

GALAXY

A

Kw Total	15,9 Kw	77,3 %*
Kw Nominal	12,3 Kw	A 679 x B 326 x C 280 Interior mm
Kg	115 Kg	320 m ³



TAURUS

A

Kw Total	18,7 Kw*	77,1 %*
Kw Nominal	14,4 Kw*	A 879 x B 326 x C 280 Interior mm
Kg	138 Kg	374 m ³ *

FERLUX . E S



Incluye marco de 3 lados de 4 cm, opcional marco de 4 lados de 4 cm.

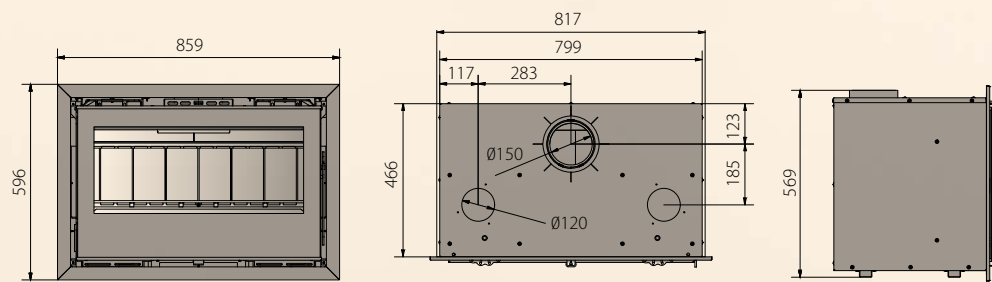

Incluye marco de 3 lados de 4 cm, opcional marco de 4 lados de 4 cm.

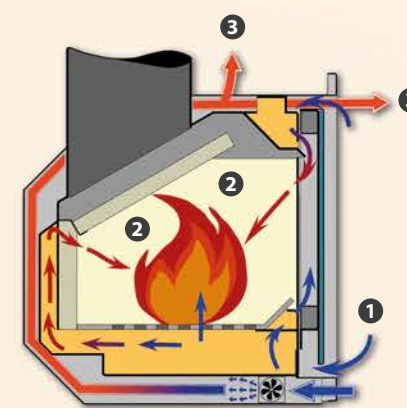

- ES** 1. Aire primario (combustión)
2. Aire secundario (combustión)
3. Salida de aire caliente
- PT** 1. Ar primário (combustão)
2. Ar secundário (combustão)
3. Saída de ar quente
- EN** 1. Primary air (combustion)
2. Secondary air (combustion)
3. Hot air outlet
- FR** 1. Air primaire (combustion)
2. Air secondaire (combustion)
3. Sortie d'air chaud
- IT** 1. Aria primaria (combustione)
2. Aria secundaria (combustione)
3. Uscita aria calda

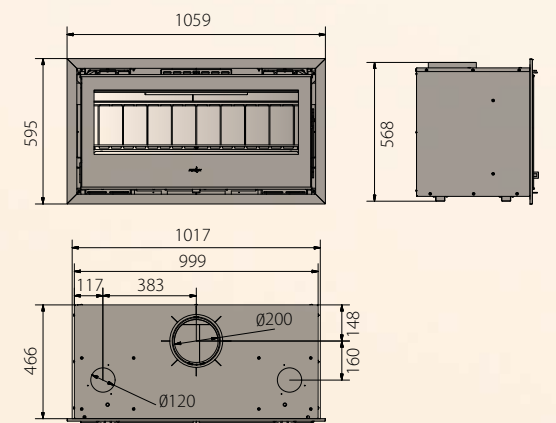



* Datos provisionales, en espera de test report.

INSERTABLES

GALAXY MINIMAL

A+

Kw Total	15,9 Kw		76 %*
Kw Nominal	12,3 Kw		A 679 x B 326 x C 280 Interior mm
Kg	139 Kg		320 m ³



FERLUX . E S



No contempla instalación de turbinas.

Incluye estructura de soporte a pared.

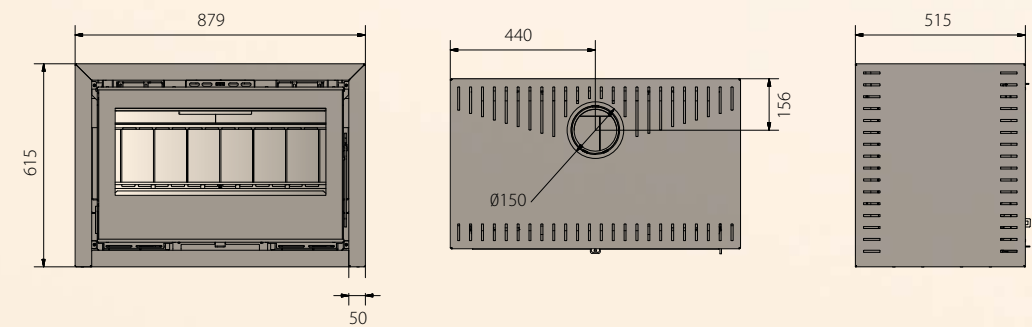



INSERTABLES

GALAXY

LEÑERO

A+



Kw Total	15,9 Kw		77,3 %
Kw Nominal	12,3 Kw		A 679 x B 326 x C 280 Interior mm
Kg	170 Kg		320 m³



GALAXY

MUEBLE

A+

Kw Total	15,9 Kw		77,3 %
Kw Nominal	12,3 Kw		A 679 x B 326 x C 280 Interior mm
Kg	180 Kg		320 m³



No contempla instalación de turbinas.

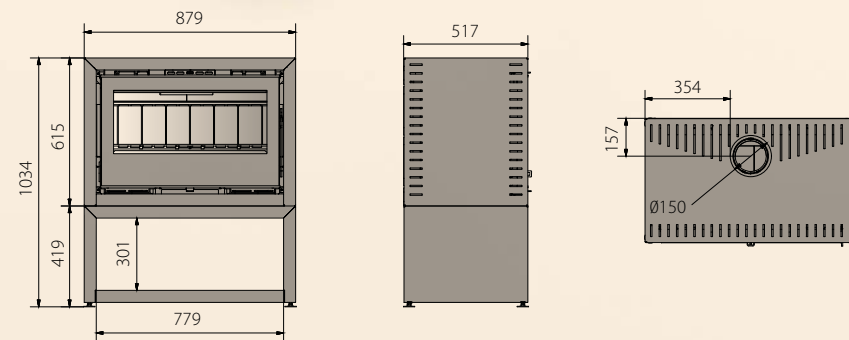

No contempla instalación de turbinas.

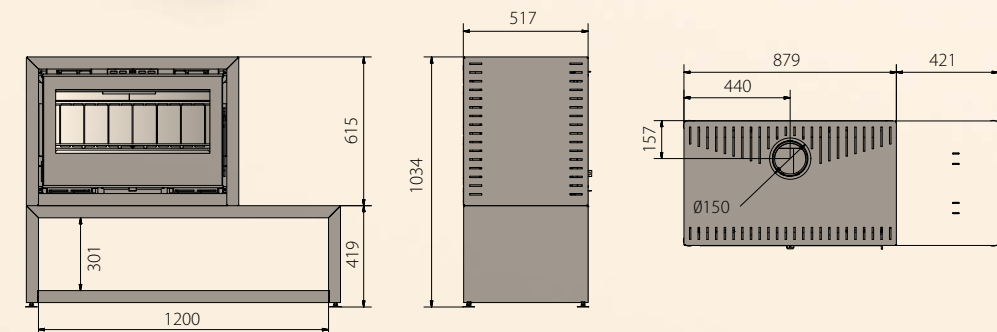

PANORAMIC 700



A+

PANORAMIC700 2C

Kw Total	16 Kw*		76,5 %*
Kw Nominal	12,3 Kw*		A 614 x B 301 x C 293 Interior mm
Kg	131 Kg		320 m³*

A+

PANORAMIC700 3C

Kw Total	15,9 Kw*		76,8 %*
Kw Nominal	12,2 Kw*		A 595 x B 301 x C 293 Interior mm
Kg	126 Kg		317 m³*

A+

PANORAMIC700 1C

Kw Total	15,7 Kw*		76,7 %*
Kw Nominal	12,2 Kw*		A 633 x B 301 x C 293 Interior mm
Kg	137 Kg		317 m³*

Disponible con ventana en cara derecha o izquierda.



PANORAMIC700 1C
Incluye marco de 3 cm.

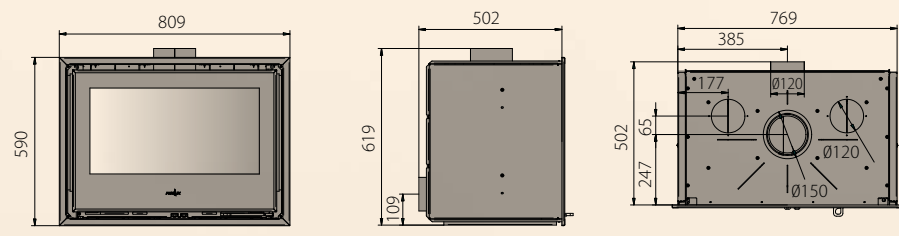

PANORAMIC700 2C
Incluye marco de 3 cm.

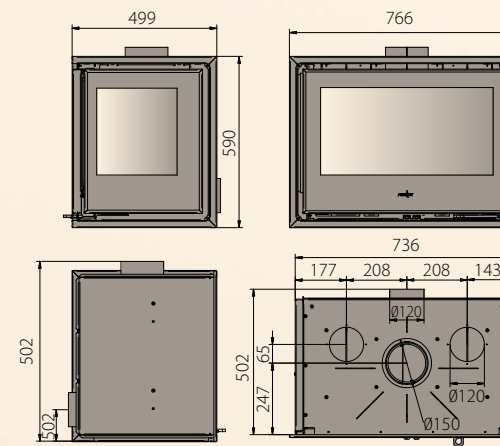

PANORAMIC700 3C
Incluye marco de 3 cm.

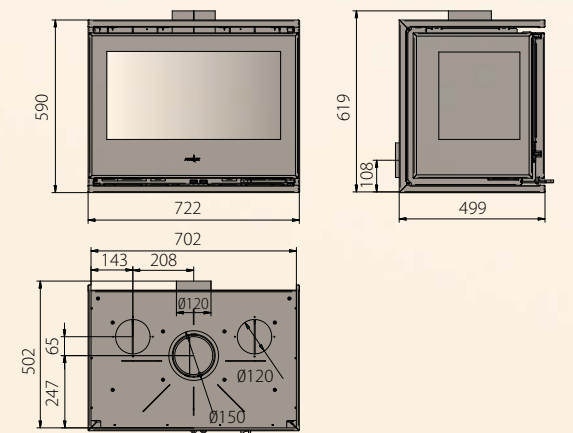

* Datos provisionales, en espera de test report.



* Datos provisionales, en espera de test report.

FERLUX.ES

INSERTABLES

PANORAMIC 900



A+

PANORAMIC900 2C

Kw Total	18,7 Kw		77,8 %
Kw Nominal	14,6 Kw		A 798 x B 301 x C 293 Interior mm
Kg	151 Kg		380 m ³

A+

PANORAMIC900 3C

Kw Total	18,7 Kw		77,9 %
Kw Nominal	14,6 Kw		A 779 x B 301 x C 293 Interior mm
Kg	151 Kg		380 m ³

A+

PANORAMIC900 1C

Kw Total	18,6 Kw		77,9 %
Kw Nominal	14,5 Kw		A 817 x B 301 x C 293 Interior mm
Kg	157 Kg		377 m ³



Disponible con ventana en cara derecha o izquierda.

FERLUX . E S

INSERTABLES



PANORAMIC900 1C
Incluye marco de 3 cm.

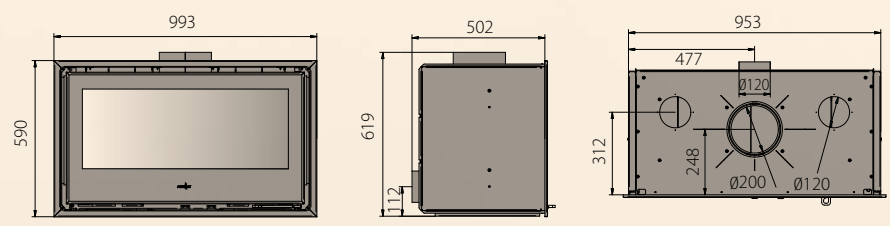

PANORAMIC900 2C
Incluye marco de 3 cm.

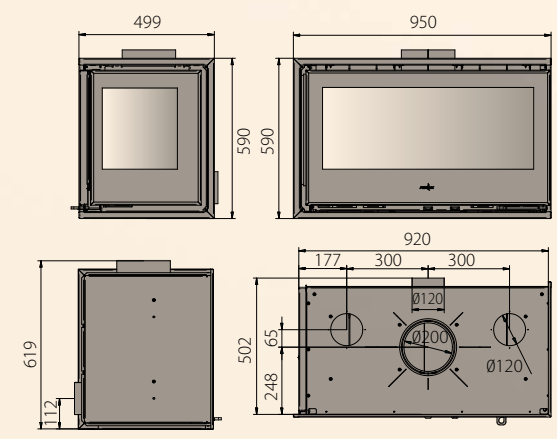

PANORAMIC900 3C
Incluye marco de 3 cm.

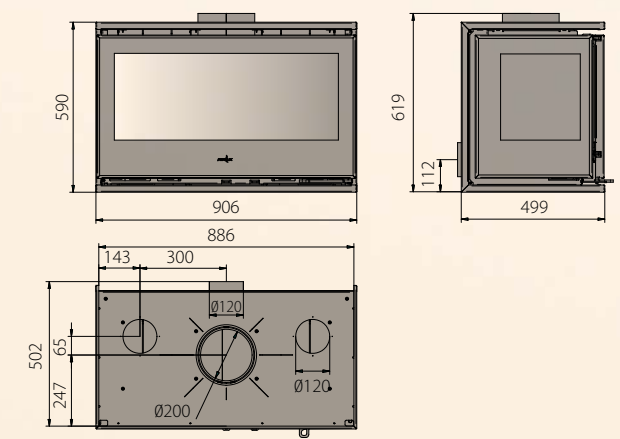

753

A

Kw Total	13,4 Kw*	77 %*
Kw Nominal	12,4 Kw*	A 622 x B 294 x C 311 Interior mm
Kg	137,7 Kg	322 m ³ *



755

A

Kw Total	13,4 Kw*	77 %*
Kw Nominal	12,4 Kw*	A 622 x B 294 x C 365 Interior mm
Kg	140,5 Kg	322 m ³ *



Opcional: marco de 3 lados de 3 cm.

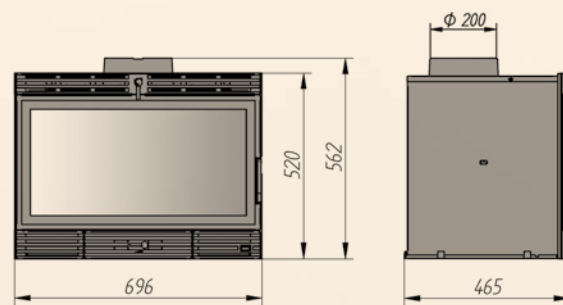

Opcional: marco de 3 lados de 3 cm.

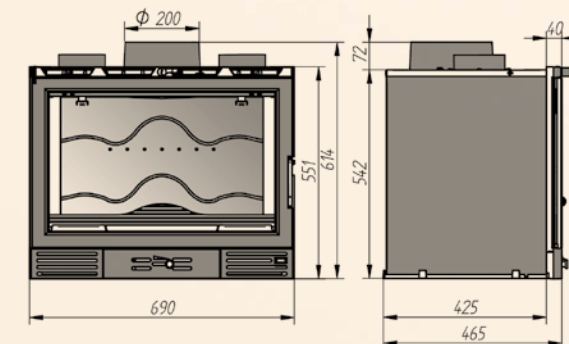

760 SERIGRAFIADO

860



A

Kw Total	13,4 Kw*	77 %*
Kw Nominal	12,4 Kw*	A 622 x B 294 x C 365 Interior mm
Kg	141 Kg	322 m³*

A

Kw Total	13,4 Kw*	77 %*
Kw Nominal	12,4 Kw*	A 622 x B 294 x C 365 Interior mm
Kg	142 Kg	322 m³*



Incluye marco de 3 lados de 5 cm.



Opcional: marco de 3 lados de 3 cm.

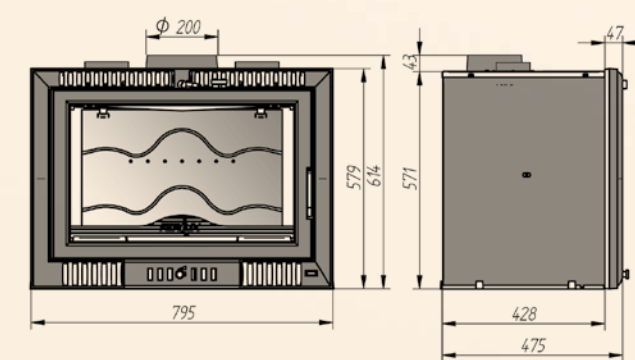
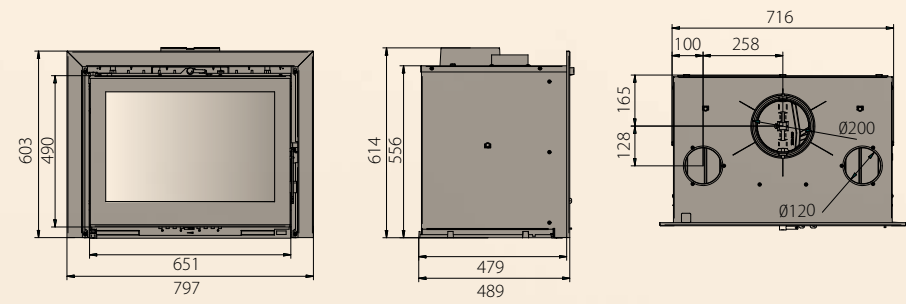



GAMA TERMOCHIMENEAS

Diseñadas para integrarse en cualquier ambiente, garantizando un confort en toda la casa. Las termochimeneas permiten calentar la vivienda de forma uniforme a través de una instalación hidráulica mediante radiadores o suelo radiante.

- K80
- K100

K80

A

Kw Total	24 Kw*		76,8 %*
Kw Total AGUA	16 Kw*		A 785 x B 514 x C 514 Interior mm
Kw Nominal	18 Kw*		237 Kg
Kw Nominal AGUA	11 Kw*		468 m ³



K100

A+

Kw Total	32 Kw*		77,4 %*
Kw Total AGUA	21 Kw*		A 1015 x B 527 x C 519 Interior mm
Kw Nominal	24 Kw*		276 Kg
Kw Nominal AGUA	15 Kw*		624 m ³

FERLUX . E S

Incluye marco de 4 lados de 4 cm.

Incluye deflector de vermiculita.



Incluye marco de 4 lados de 4 cm.

Incluye deflector de vermiculita.



- Entrada y salida de agua 1" H.
- Purga y válvula de seguridad 1/2" H.
- Presión máxima de trabajo 3 bar.

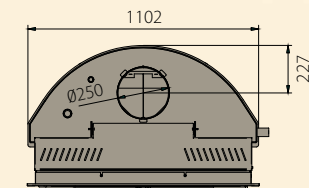
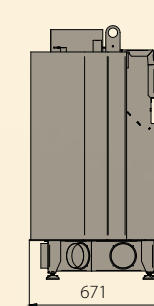
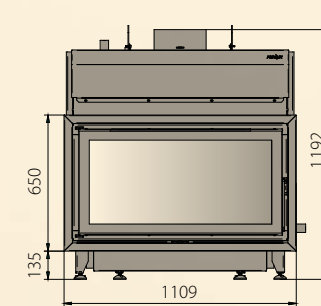
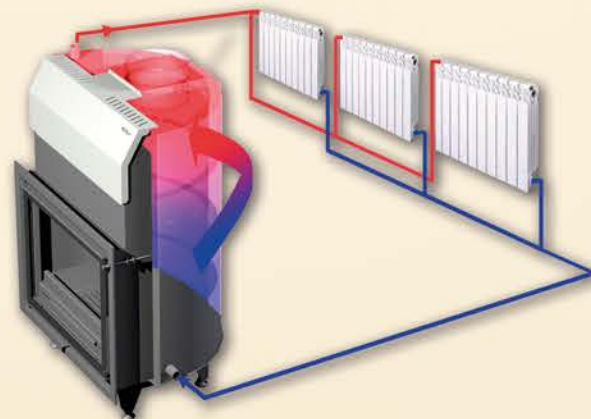
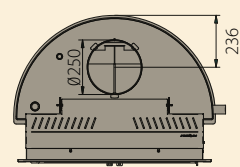
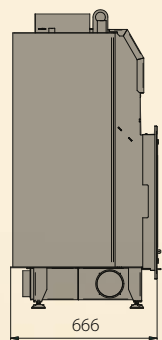
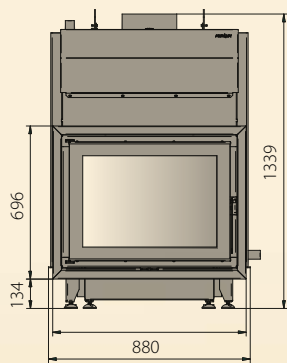

* Datos provisionales, en espera de test report.



* Datos provisionales, en espera de test report.

TERMOCHIMENEAS



GAMA ESTUFAS

Diseño moderno de las líneas curvas, con una versatilidad para su instalación que satisface cualquier necesidad. Su trazado panorámico permite disfrutar de la visión del fuego desde cualquier punto de la estancia.

- ELYPSE PIE CENTRAL
- ELYPSE LEÑERO
- ELYPSE MUEBLE

ELYPSE



A

Kw Total	10,2 Kw	78,5 %*
Kw Nominal	8 Kw	A 470 x B 345 x C 502 Interior mm
Kg	113 Kg 113 Kg 123 Kg	200 m³

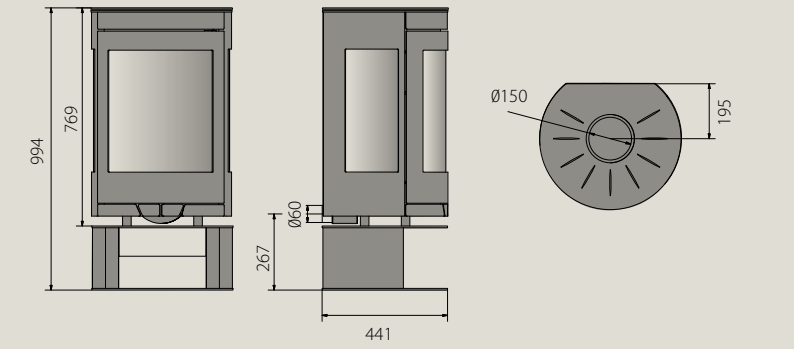

ELYPSE LEÑERO

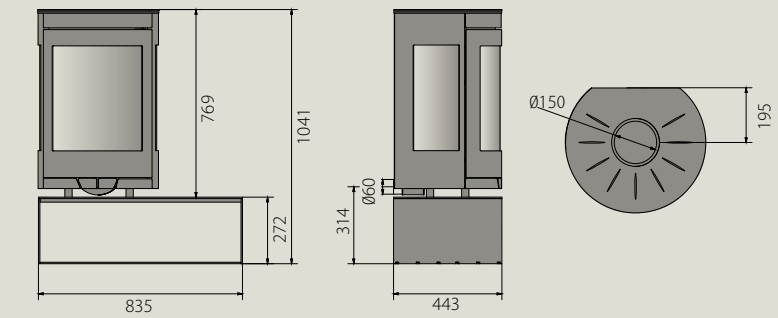

ELYPSE MUEBLE



FERLUX . E S



ELYPSE PIE CENTRAL



ELYPSE LEÑERO



ELYPSE MUEBLE

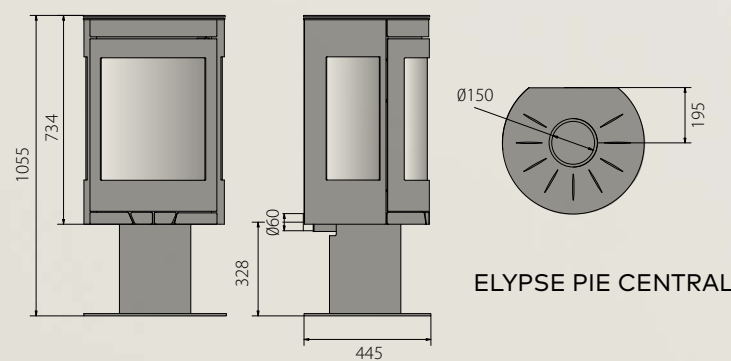



ELYPSE PIE CENTRAL



ESTUFAS

SOFÍA

A+

Kw Total	12,1 Kw		80,7%*
Kw Nominal	9,8 Kw		A 654 x B 369 x C 349 Interior mm
Kg	135 Kg		255 m ³

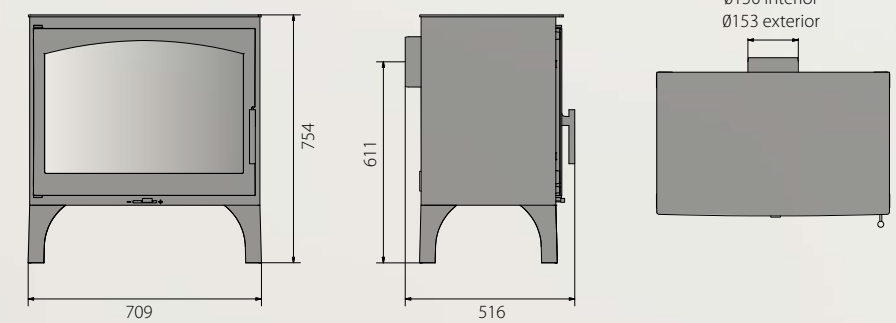



GAMAHORNOS



Ideal para aquellos que quieran disfrutar de la calidez de la leña unido al placer de la cocina.

- FORNO

FORNO

VISTO | ENCASTRABLE | LEÑERO

A+

Kw Total	19,4 Kw*		76,2%*
Kw Nominal	14,8 Kw		A 633 x B 504 x C 342 Interior mm
Kg	210 Kg 193 Kg 238 Kg		A 554 x B 513 x C 359 Horno mm
m³	385 m ³		

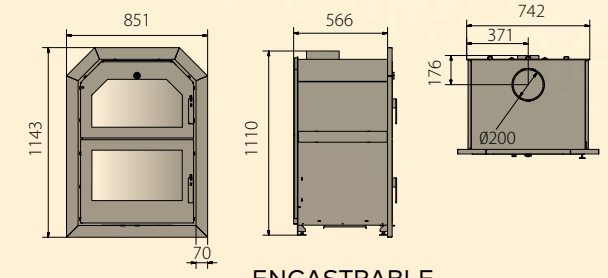

ENCASTRABLE

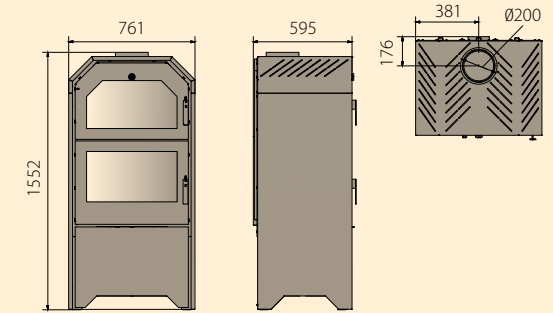

LEÑERO



ENCASTRABLE

Horno desmontable en acero inoxidable con termómetro, bandeja, parrilla horno y parrilla asado incluidas.



LEÑERO

VISTO

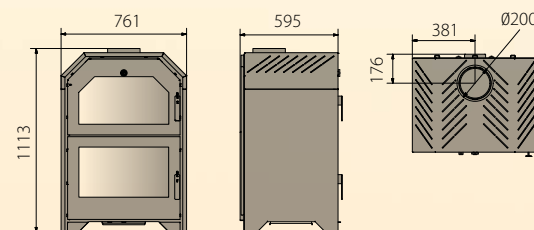

* Datos provisionales, en espera de test report.



GAMABARBACOAS

Barbacoa modular que se adapta en función de la necesidad y gusto de todas las familias. Los componentes en contacto con los alimentos son de acero inoxidable. Parrilla regulable en altura que incorpora sistema recoge grasa.

- PRÁCTIC 80
- PATIO
- FIESTA
- VERBENA
- JARDÍN
- SERIE S

PRÁCTIC80

	A 785 x B 503 x C 516 Interior mm
	A 593 x B 440 x C 223 Horno mm
	230 Kg



PATIO

	95,8 Kg
--	----------------

FERLUX . E S



Horno desmontable en acero inoxidable con termómetro, bandeja, parrilla horno y parrilla asado incluidas.

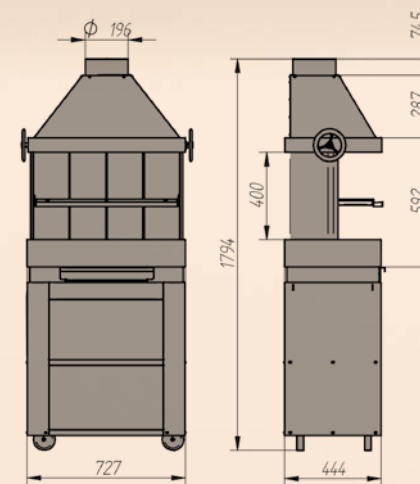
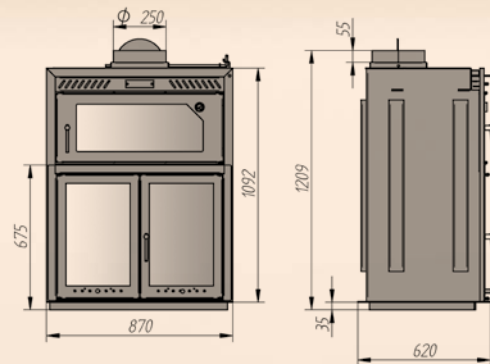

Combustible: Carbón vegetal
Combustível: Carvão vegetal
Fuel: Charcoal
Combustible: charbon de bois



FIESTA

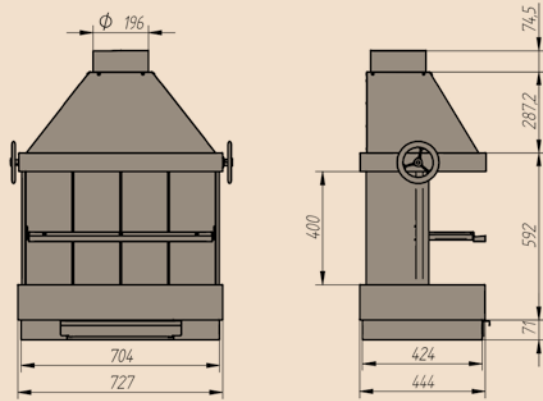

VERBENA

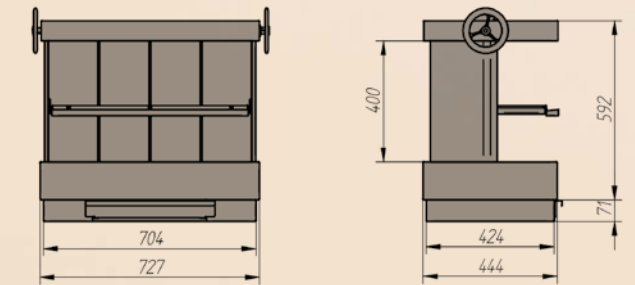

FERLUX . E S



	Fiesta	Verbena	Jardín
Kg	60,8 Kg	59,1 Kg	56,6 Kg



JARDÍN

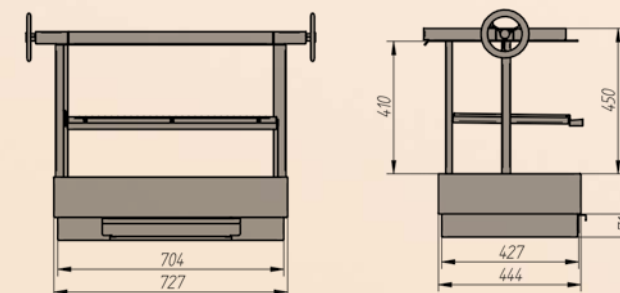

Combustible: Carbón vegetal
Combustível: Carvão vegetal
Fuel: Charcoal
Combustible: charbon de bois

SERIES

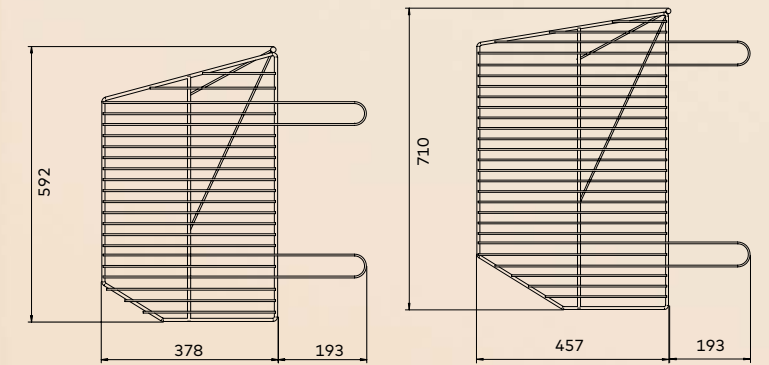

Opcional parrilla para asado S-70

Opcional parrilla para asado S-80 y S-100

PUERTAS PARA HOGAR Opcional

PUERTA DE 1 HOJA

Modelo	A	B	C	D	E	Cristal Glass	Peso (Kg) Weight (Kg)
70	684	522	765	571	30	613 x 430 x 4	14

PUERTA DE 2 HOJAS

Modelo	A	B	C	D	E	Cristal Glass	Peso (Kg) Weight (Kg)
80	775	579	855	631	30	312 x 494 x 4 (x2)	17
100	984	628	1064	680	30	416 x 545 x 4 (x2)	19

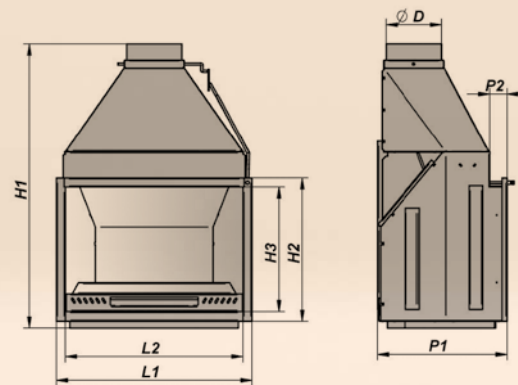
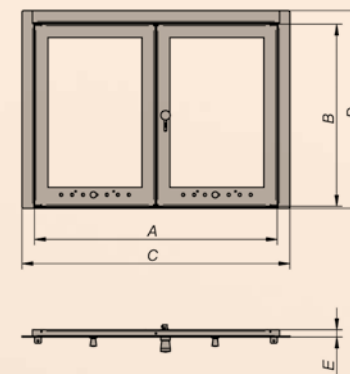
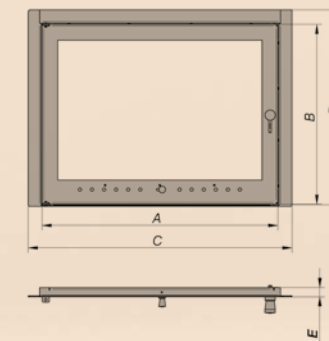

S70



S80 | S100

Serie Kind	Modelo Model	mm Exterior					mm Interior			Kg	
		H1	H2	L1	P1	P2	H3	L2	Prof. Depth		
S	70	1170	578	780	594	78	538	700	460	200	99,6
	80	1244	641	870	594	78	598	790	460	250	112,5
	100	1407	691	1080	659	78	648	1000	523	300	165,8

ACCESORIOS OPCIONALES PELLETT

SALIDA DE HUMO VERTICAL

Instala cómodamente aprovechando el máximo de espacio, sin necesidad de dejar la estufa separada de la pared.

Install comfortably making the most of the space, without having to leave the stove separated from the wall.

Instale confortavelmente aproveitando o espaço, sem ter que deixar o recuperador separado da parede.

Installare comodamente sfruttando al massimo lo spazio, senza dover lasciare la stufa separata dal muro.

Installez confortablement en tirant le meilleur parti de l'espace, sans avoir à laisser le poêle séparé du mur.

MODELO A

Para los aparatos:

- SHARA
- HELEN GLASS
- HELEN STEEL
- ELISA
- VENUS



MODELO B

Para los aparatos:

- ARES
- OSIRIS



TUBO ADICIONAL DE LLENADO

Realiza el llenado del insertable fácilmente y rápidamente, aumentando la capacidad de almacenaje del combustible.

Fills the insert easily and quickly, increasing the fuel storage capacity.

Enche o inserto de forma fácil e rápida, aumentando a capacidade de armazenamento de combustível.

Riempie l'inserto facilmente e rapidamente, aumentando la capacità di stoccaggio del carburante.

Remplit l'insert facilement et rapidement, augmentant la capacité de stockage de carburant.

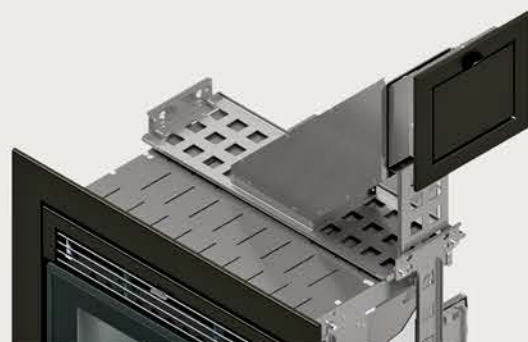

BASE DE APOYO CON ALTURA REGULABLE



Instala de forma ágil y segura con la posibilidad de elegir tres alturas diferentes.

Install in an agile and safe way with the possibility of choosing three different heights.

Instale de forma ágil e segura com possibilidade de escolha de três alturas diferentes.

Installa in modo agile e sicuro con la possibilità di scegliere tre diverse altezze.

Installez de manière agile et sûre avec la possibilité de choisir trois hauteurs différentes.

TAPÓN SALIDA DE HUMOS FLORA SV

Para instalación trasera

For rear installation

Para instalação traseira

Per installazione posteriore

Pour installation arrière



CONVOYADOR LYRA

Para pasar de dos a una canalización, (ø 100mm)

To go from two to one pipeline, (ø 100 mm)

Para ir de dois para um pipeline, (ø 100 mm)

Per passare da due a una pipeline, (ø 100 mm)

Pour passer de deux à un pipeline, (ø 100 mm)



4 HEAT

Con este sistema podemos monitorizar y controlar desde nuestro propio móvil o tablet todas las funciones de la estufa y/o calderas, a través de una aplicación compatible con "ANDROID", "IOS" y "Windows PHONE", desde cualquier parte del mundo permitiéndonos mayor confort.

Sistema che permette di controllare e visualizzare tramite telefono cellulare o Tablet tutte le funzioni della stufa e/o caldaia tramite un'applicazione compatibile con tutti i sistema operativi "ANDROID", "IOS" y "Windows PHONE", da qualsiasi parte del mondo permettendoci un maggiore confort.

This system allows you to monitor and control all the functions of the heater and/or boiler using your own mobile phone or tablet by using an application compatible with 'ANDROID', 'IOS', and 'Windows PHONE', from anywhere in the world allowing us greater comfort.

Avec ce système, on peut surveiller et contrôler à partir de notre mobile ou tablette toutes les fonctions du poêle et/ou chaudières à travers une application compatible avec «ANDROID» «IOS» et «Windows PHONE», de n'importe où dans le monde nous permettant un plus grand confort.

Com este sistema podemos monitorizar e controlar, a partir do próprio telemóvel ou tablet, todas as funções do fogão e/ou caldeiras através de uma aplicação compatível com "ANDROID", "IOS" e "Windows PHONE", de qualquer lugar do mundo permitindo-nos um maior conforto.



CARACTERÍSTICAS TÉCNICAS

GAMA AIRE

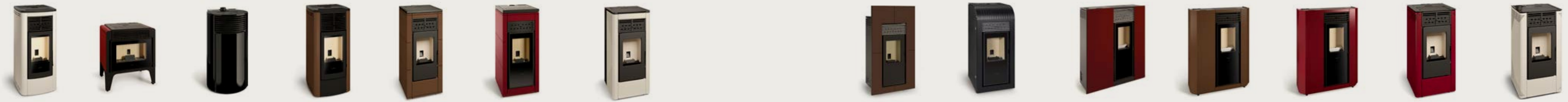

	SHARA 6 8 10 Kw	ARES 6 8 10 Kw	HELEN GLASS / STEEL 6 8 10 Kw	ELISA 6 8 10 Kw	NEREA 8 10Kw	VENUS 6 8 10 Kw	NATALIA 10 Kw	LUNA 8 10 Kw	AROA 8 10 Kw	GÉNESIS GLASS / STEEL 6 8 Kw	MAIA 6 8 Kw	MAIA 10 Kw	FLORA 7 8 Kw	FLORA SV 8 10Kw
Kw Total	6,8 9,3 10,8	6,9 9,3 11,2	6,8 9,3 10,8	6,8 9,3 10,8	9,3 10,8	6,8 9,3 10,8	10,8	9,3 10,8	9,3 10,8	6,5 8,8	6,5 8,8	11,3	7,9 9,3	9,3 10,8
Kw Nominal	6,1 8,2 9,5	6,3 8,5 10,2	6,1 8,2 9,5	6,1 8,2 9,5	8,2 9,5	6,1 8,2 9,5	9,5	8,2 9,5	8,2 9,5	6,2 8,1	6,2 8,1	10,1	7,1 8,2	8,2 9,5
Kw Min-Max	2,8 - 6,1 2,8 - 8,2 2,8 - 9,5	3,4 - 6,3 3,4 - 8,5 3,4 - 10,2	2,8 - 6,1 2,8 - 8,2 2,8 - 9,5	2,8 - 6,1 2,8 - 8,2 2,8 - 9,5	2,8 - 8,2 2,8 - 9,5	2,8 - 6,1 2,8 - 8,2 2,8 - 9,5	2,8 - 9,5	2,8 - 8,2 2,8 - 9,5	2,8 - 8,2 2,8 - 9,5	2,4 - 6,2 2,4 - 8,1	2,4 - 6,2 2,4 - 8,1	2,4 - 10,1	2,8 - 7,1 2,8 - 8,2	2,8 - 8,2 2,8 - 9,5
Min-Max	94 - 90 94 - 88 94 - 88	94 - 91 94 - 90 94 - 88	94 - 90 94 - 88 94 - 88	94 - 90 94 - 88 94 - 88	94 - 88 94 - 88	94 - 90 94 - 88 94 - 88	94 - 88	94 - 88 94 - 88	94 - 88 94 - 88	96 - 93 96 - 92	96 - 93 96 - 92	96 - 91	94 - 90 94 - 88	94 - 88 94 - 88
mm	474 x 530 x 985	700 x 571 x 805	550 x 608 x 978	474 x 530 x 985	450 x 497 x 985	437 x 530 x 1006	452 x 498 x 985	606 x 504 x 1121	460 x 498 x 1053	897 x 295 x 1086	800 x 259 x 1046	800 x 259 x 1046	458 x 499 x 917	480 x 529 x 917
Kg	125	122	115 / 118	126	110	103	110	110	110	120	107	107	95	95
Kg	21	21	21	21	22	21	22	22	26	20	13,5	13,5	17	12
Min-Max	35 - 15 35 - 11 35 - 10	30 - 15 30 - 11 30 - 9	35 - 15 35 - 11 35 - 10	35 - 15 35 - 11 35 - 10	37 - 12 37 - 10	35 - 15 35 - 11 35 - 10	37 - 10	37 - 12 37 - 10	43 - 14 43 - 12	40 - 15 40 - 11	27 - 10 27 - 8	27 - 6	28 - 11 28 - 9	20 - 6 20 - 5
mm	80	80	80	80	80	80	80	80	80	80	80	80	80	80
mm	40	40	40	40	40	40	40	40	40	40	40	40	40	40
m³	150 195 245	150 195 245	150 195 245	150 195 245	195 245	150 195 245	245	195 245	195 245	150 195	150 195	245	165 195	195 245
Kg/h Min-Max	0,6 - 1,4 0,6 - 1,9 0,6 - 2,2	0,7 - 1,4 0,7 - 1,9 0,7 - 2,3	0,6 - 1,4 0,6 - 1,9 0,6 - 2,2	0,6 - 1,4 0,6 - 1,9 0,6 - 2,2	0,6 - 1,9 0,6 - 2,2	0,6 - 1,4 0,6 - 1,9 0,6 - 2,2	0,6 - 2,2	0,6 - 1,9 0,6 - 2,2	0,6 - 1,9 0,6 - 2,2	0,5 - 1,3 0,5 - 1,8	0,5 - 1,3 0,5 - 1,8	0,5 - 2,3	0,6 - 1,6 0,6 - 1,9	0,6 - 1,9 0,6 - 2,2
SI	SI	SI	SI	SI	SI	SI	SI	SI	SI	NO	NO	NO	SI	SI

FERLUX . ES

CARACTERÍSTICAS TÉCNICAS

Cotas y medidas en mm / Heights and sizes in mm.
Ferlux se reserva el derecho a modificar cualquier modelo de este catálogo sin previo aviso.
Cotas a título orientativo.

Kw Total	Potencia total (Kw) Total power (Kw)	Kg	Peso (Kg) Weight (Kg)	m³	Volúmen calefactable (m³) Heating capacity (m³)
Kw Nominal	Potencia (Kw) Power (Kw)	Kg	Tolva (Kg) Tank (Kg)	Kg/h Min-Max	Consumo min-max (Kg/h) Consumption min-max (Kg/h)
Kw Min-Max	Potencia min-max (Kw) Power min-max (Kw)	Min-Max	Autonomía min-max (h) Autonomy min-max (h)	Brasero de fundición	Cast iron burners
Min-Max	Rendimiento (%) Yield (%)	mm	Diámetro chimenea (mm) Chimney diameter (mm)		
mm	Medidas (mm) Measures (mm)	mm	Entrada de aire Air inlet		

CARACTERÍSTICAS TÉCNICAS

GAMA AIRE

GAMA CANALIZABLE

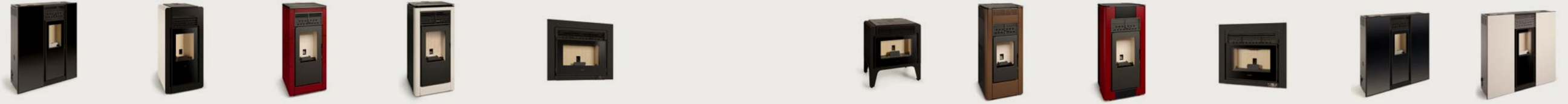

	GÉNESIS GLASS / STEEL 10 12 Kw	IRIS 12 15 Kw	NEREA 12 15 Kw	ESTELA 12 15 Kw	ULYSES 8 10 Kw Insertable	OSIRIS 8 10 Kw	NORA 8 10 Kw	LYRA 12 15 Kw	ÍKARO 8 10 Kw Insertable	PHOENIX GLASS 10 12 Kw	PHOENIX STEEL 10 12 Kw
Kw Total	11,3 12,2	14 16,6	14 16,6	14 16,6	9,3 11,2	9,3 11,2	9,3 10,8	14 16,6	9,3 11,2	11,3 12,2	11,3 12,2
Kw Nominal	10,1 11,1	12,5 14,7	12,5 14,7	12,5 14,7	8,5 10,2	8,5 10,2	8,2 9,5	12,5 14,7	8,5 10,2	10,1 11,1	10,1 11,1
Kw Min-Max	2,4 - 10,1 2,4 - 11,1	4,6 - 12,5 4,6 - 14,7	4,6 - 12,5 4,6 - 14,7	4,6 - 12,5 4,6 - 14,7	3,4 - 8,5 3,4 - 10,2	3,4 - 8,5 3,4 - 10,2	2,8 - 8,2 2,8 - 9,5	4,6 - 12,5 4,6 - 14,7	3,4 - 8,5 3,4 - 10,2	2,4 - 10,1 2,4 - 11,1	2,4 - 10,1 2,4 - 11,1
Min-Max	96 - 91 96 - 89	92 - 88 92 - 87	92 - 88 92 - 87	92 - 88 92 - 87	94 - 90 94 - 88	94 - 90 94 - 88	94 - 88 94 - 88	92 - 88 92 - 87	94 - 90 94 - 88	96 - 91 96 - 89	96 - 91 96 - 89
mm	897 x 295 x 1086	524 x 540 x 1122	514 x 541 x 1104	520 x 542 x 1104	640 x 556 x 579	700 x 571 x 805	478 x 499 x 1097	561 x 542 x 1190	640 x 577 x 611	1070 x 295 x 1086	1070 x 295 x 1086
Kg	120	136	132	132	99	122	130	160	105	130	130
Kg	20	30	30	30	13	21	22	29	15	20	20
Min-Max	40 - 9 40 - 8	30 - 10 30 - 9	30 - 10 30 - 9	30 - 10 30 - 9	19 - 7 19 - 6	30 - 11 30 - 9	37 - 12 37 - 10	29 - 10 29 - 9	19 - 7 19 - 6	40 - 9 40 - 8	40 - 9 40 - 8
mm	80	80	80	80	80	80	80	80	80	80	80
mm	40	60	60	60	40	40	40	60	40	40	40
m³	245 325	325 375	325 375	325 375	195 245	195 245	195 245	325 375	195 245	245 325	245 325
Kg/h Min-Max	0,5 - 2,3 0,5 - 2,5	1 - 2,9 1 - 3,4	1 - 2,9 1 - 3,4	1 - 2,9 1 - 3,4	0,7 - 1,9 0,7 - 2,3	0,7 - 1,9 0,7 - 2,3	0,6 - 1,9 0,6 - 2,2	1 - 2,9 1 - 3,4	0,7 - 1,9 0,7 - 2,3	0,5 - 2,3 0,6 - 2,5	0,5 - 2,3 0,6 - 2,5
NO	NO	SI	SI	SI	SI	SI	SI	SI	SI	NO	NO
1						1	2	2	1	1	1

FERLUX . E S

C A R A C T E R Í S T I C A S T É C N I C A S

Cotas y medidas en mm / Heights and sizes in mm.
Ferlux se reserva el derecho a modificar cualquier modelo de este catálogo sin previo aviso.
Cotas a título orientativo.

Kw Total	Potencia total (Kw) Total power (Kw)	Kg	Peso (Kg) Weight (Kg)	m³	Volúmen calefactable (m³) Heating capacity (m³)
Kw Nominal	Potencia (Kw) Power (Kw)	Kg	Tolva (Kg) Tank (Kg)	Kg/h Min-Max	Consumo min-max (Kg/h) Consumption min-max (Kg/h)
Kw Min-Max	Potencia min-max (Kw) Power min-max (Kw)	Min-Max	Autonomía min-max (h) Autonomy min-max (h)	Brasero de fundición	Cast iron burners
Min-Max	Rendimiento (%) Yield (%)	mm	Diámetro chimenea (mm) Chimney diameter (mm)	Canalización	Canalization
mm	Medidas (mm) Measures (mm)	mm	Entrada de aire Air inlet		

CARACTERÍSTICAS TÉCNICAS

GAMA AGUA



GAMA CALDERAS



	IRIS HIDRO 15 18	IRIS HIDRO 27	LUNA HIDRO 15 18	LUNA HIDRO 27	SELENA 15 18	SELENA 27	ALTEA 15 18	ALTEA 27	HIDROMATIC 18	HIDROMATIC 24	
Kw Total	17,8 21,2	27,9	17,8 21,2	27,9	17,8 21,2	27,9	17,8 21,2	27,9	-	-	Kw Total
Kw Min-Max	5,3 - 16,7 5,3 - 19,8	6,8 - 25,8	5,3 - 16,7 5,3 - 19,8	6,8 - 25,8	5,3 - 16,7 5,3 - 19,8	6,8 - 25,8	5,3 - 16,7 5,3 - 19,8	6,8 - 25,8	3,62 - 12,14 Kw 5,86 - 18,26 Kw	7,97 - 24,11 Kw 9,16 - 31,29 Kw 10,76 - 35,58 Kw	Kw Min-Max
Kw Min-Max	3,6 - 13,6 3,6 - 16,2	5,1 - 21,6	3,6 - 13,6 3,6 - 16,2	5,1 - 21,6	3,6 - 13,6 3,6 - 16,2	5,1 - 21,6	3,6 - 13,6 3,6 - 16,2	5,1 - 21,6	12 18	24 30 35	Kw Min-Max
Min-Max	96 - 95 96 - 94	95 - 93	96-95 96-94	95 - 93	96 - 95 96 - 94	95 - 93	96 - 95 96 - 94	95 - 93	96 - 95 96 - 95	95 - 94 97 - 94 96 - 93	Min-Max
mm	616 x 605 x 1136	616 x 605 x 1236	760 x 600 x 1324	760 x 600 x 1424	543 x 605 x 1116	543 x 605 x 1216	543 x 605 x 1116	543 x 605 x 1216	622 x 837 x 1503	702 x 837 x 1603	mm
Kg	178	225	182	231	170	218	170	218	320	360	Kg
Kg	35	45	35	45	35	45	35	45	90 Aprox.	103 Aprox.	Kg
Min-Max	32 - 10 32 - 8,3	32 - 8	32 - 10 32 - 8,3	32 - 8	32 - 10 32 - 8,3	32 - 8	32 - 10 32 - 8,3	32 - 8	129 - 33 82 - 23	69 - 19 54 - 15 47 - 13	Min-Max
80	80	80	80	80	80	80	80	80	80 Aumento obligatorio de 80 a 100mm	100 Aumento obligatorio de 100 a 120mm	80
60	60	60	60	60	60	60	60	60	60	60	60
m³	250 375	690	250 375	690	250 375	690	250 375	690	250 350	500 600 700	m³
Kg/h Min-Max	1,1 - 3,6 1,1 - 4,2	1,4 - 5,6	1,1 - 3,6 1,1 - 4,2	1,4 - 5,6	1,1 - 3,6 1,1 - 4,2	1,4 - 5,6	1,1 - 3,6 1,1 - 4,2	1,4 - 5,6	0,7 - 2,7 1,1 - 4,0	1,5 - 5,4 1,9 - 6,8 2,2 - 8,0	Kg/h Min-Max
SI	SI	NO	SI	NO	SI	NO	SI	NO	-	-	SI
8	8	8	8	8	8	8	8	8	-	-	8

FERLUX . E S

CARACTERÍSTICAS TÉCNICAS

Kw Total	Potencia total (Kw) Total power (Kw)	Kg	Peso (Kg) Weight (Kg)	m³	Volúmen calefactable (m³) Heating capacity (m³)
Kw Nominal	Potencia (Kw) Power (Kw)	Kg	Telva (Kg) Tank (Kg)	Kg/h Min-Max	Consumo min-max (Kg/h) Consumption min-max (Kg/h)
Kw Min-Max	Potencia min-max (Kw) Power min-max (Kw)	Min-Max	Autonomía min-max (h) Autonomy min-max (h)	Brasero de fundición	Cast iron burners
Min-Max	Rendimiento (%) Yield (%)	mm	Diámetro chimenea (mm) Chimney diameter (mm)	Canalización	Canalization
mm	Medidas (mm) Measures (mm)	mm	Entrada de aire Air inlet	Vaso de expansión	Expansion vessel

CARACTERÍSTICAS TÉCNICAS

GAMA INSERTABLES

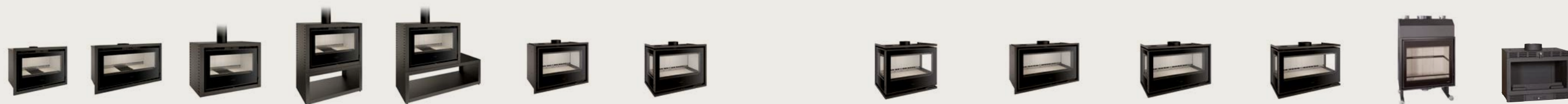

	GALAXY	TAURUS	GALAXY MINIMAL	GALAXY LEÑERO	GALAXY MUEBLE	PANORAMIC 700 1C	PANORAMIC 700 2C	PANORAMIC 700 3C	PANORAMIC 900 1C	PANORAMIC 900 2C	PANORAMIC 900 3C	IMAZ	753
	569	569	615	1034	1034	619	619	619	619	619	619	1433	520
	817	1017	879	879	1300	781	736	702	953	933	900	888	696
	466	466	515	517	517	502	502	502	502	502	502	546	465
	150	200	150	150	150	150	150	150	200	200	200	250	200
	115	138	139	170	180	137	131	126	157	151	146	250	137,7
Pa	12 - 15	12 - 15	12 - 15	12 - 15	12 - 15	12 - 15	12 - 15	12 - 15	12 - 15	12 - 15	12 - 15	12 - 15	12 - 15
Kw Total	15,9	18,7*	15,9	15,9	15,9	15,7*	16*	15,9*	15,9	18,6	18,7	16	13,4*
Kw Nominal	12,3	14,4*	12,3	12,3	12,3	12,2*	12,3*	12,2*	14,5	14,6	14,6	14,5	12,4*
	320	374*	320	320	320	317*	320*	317*	377	380	380	400	322*
	280	280	280	280	280	293	293	293	293	293	293	643	311
	679	879	679	679	679	633	614	595	817	798	779	760	622
	326	326	326	326	326	301	301	301	301	301	301	355	294
	464	464	464	464	464	frontal: 491	frontal: 491 lateral: 489	frontal: 491 lateral: 489	frontal: 491 lateral: 489	frontal: 491 lateral: 489	frontal: 491 lateral: 489	730	319
	738	938	738	738	738	frontal: 707	frontal: 707 lateral: 402	frontal: 707 lateral: 402	frontal: 888 lateral: 402	frontal: 888 lateral: 402	frontal: 888 lateral: 402	783	618
	600	800	600	600	600	600	600	600	600	600	600	650	500
	77,3	77,1*	77,3	77,3	77,3	76,7*	76,5*	76,8*	77,9	77,8	77,9*	80	77*

FERLUX . E S

CARACTERÍSTICAS TÉCNICAS

Cotas y medidas en mm / Heights and sizes in mm.
 Ferlux se reserva el derecho a modificar cualquier modelo de este catálogo sin previo aviso.
 * Datos provisionales, en espera de test report.

Alto	Salida Ø humos	Kw Total Potencia total	Alto cámara combustión	Alto cristal
Ancho	Peso (Kg)	Kw Nominal Potencia nominal	Ancho cámara combustión	Ancho cristal
Profundidad	Pa Depresión salida de humos	Volumen calefactable	Profundidad cámara de combustión	Longitud leños
				Rendimiento

CARACTERÍSTICAS TÉCNICAS

GAMA INSERTABLES



GAMA TERMOCHIMENEAS



GAMA ESTUFAS



	755	760 SERIGRAFIADO	860	K80	K100	ELYPSE LEÑERO	ELYPSE PIE CENTRAL	ELYPSE MUEBLE	SOFÍA
	551	556	579	1339	1192	994	1055	1041	754
	690	716	795	917	1109	441	445	835	709
	465	489	475	666	671	441	445	443	516
	200	200	200	250	250	150	150	150	150
	140,5	141	142	237	262	113	113	123	135
Pa	12 - 15	12 - 15	12 - 15	12 - 15	12 - 15	12 - 15	12 - 15	12 - 15	12 - 15
Kw Total	13,4*	13,4*	13,4*	24* / 16* Kw Total / Kw T.Agua	32* / 21* Kw Total / Kw T.Agua	10,2	10,2	10,2	12,1
Kw Nominal	12,4*	12,4*	12,4*	18* / 11* Kw Total / Kw T.Agua	24* / 15* Kw Total / Kw T.Agua	8	8	8	9,8
	322*	322*	322*	468*	624*	200	200	200	255
	365	365	365	514	519	502	502	502	349
	622	622	622	785	1015	470	470	470	654
	294	294	294	514	527	345	345	345	369
	380	484	380	535	499	Fontal: 452 Lateral: 452	Fontal: 452 Lateral: 452	Fontal: 452 Lateral: 452	420
	610	646	610	730	969	Fontal: R239/102,6° Lateral: R239/49,5°	Fontal: R239/102,6° Lateral: R239/49,5°	Fontal: R239/102,6° Lateral: R239/49,5°	615
	500	500	500	650	900	300	300	300	300
	77*	77*	77*	76,8*	77,4*	78,5	78,5	78,5	80,7

FERLUX . E S

CARACTERÍSTICAS TÉCNICAS

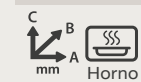

Cotas y medidas en mm / Heights and sizes in mm.
Ferlux se reserva el derecho a modificar cualquier modelo de este catálogo sin previo aviso.
* Datos provisionales, en espera de test report.

	Alto		Salida Ø humos	Kw Total	Potencia total		Alto cámara combustión
	Ancho		Peso (Kg)	Kw Nominal	Potencia nominal		Ancho cámara combustión
	Profundidad	Pa	Depresión salida de humos		Volumen calefactable		Longitud leños
							Rendimiento

CARACTERÍSTICAS TÉCNICAS

GAMA HORNO



GAMA BARBACOAS



	FORNO VISTO	FORNO ENCASTRABLE	FORNO LEÑERO	PRACTIC 80	PATIO	FIESTA	VERBENA	JARDÍN	SERIE S Modelo 70	SERIE S Modelo 80	SERIE S Modelo 100
	1113	1110	1552	1209	2131	1035	663	646	1170	1244	1407
	761	742	761	870	727	727	727	727	780	870	1080
	595	566	595	620	446	446	446	446	594	594	659
	200	200	200	250	-	-	-	-	200	250	300
	210	193	238	230	95,8	66,8	59,1	56,6	112,2	127,2	189,3
Pa	12 - 15	12 - 15	12 - 15	12 - 15					12 - 15	12 - 15	12 - 15
Kw Total	19,4*	19,4*	19,4*	-					-	-	-
Kw Nominal	14,8*	14,8*	14,8*	-					-	-	-
	385*	385*	385*	-					-	-	-
	342	342	342	516					538	598	648
	633	633	633	785					700	790	1000
	504	504	504	503					460	460	523
	Sup: 321 Inf: 329	Sup: 321 Inf: 329	Sup: 321 Inf: 329	494 (2 uds)					-	-	-
	Sup: 562 Inf: 561	Sup: 562 Inf: 561	Sup: 562 Inf: 561	312 (2 uds)					-	-	-
	500	500	500	600					500	600	600
	76,2*	76,2*	76,2*	-							

A 554 x B 513 x C 359 A 554 x B 513 x C 359 A 554 x B 513 x C 359 A 593 x B 440 x C 223
 mm Horno

Cotas y medidas en mm / Heights and sizes in mm.
 Ferlux se reserva el derecho a modificar cualquier modelo de este catálogo sin previo aviso.

* Datos provisionales, en espera de test report.

	Alto		Salida Ø humos	Kw Total	Potencia total		Alto cámara combustión		Alto cristal
	Ancho		Peso (Kg)	Kw Nominal	Potencia nominal		Ancho cámara combustión		Ancho cristal
	Profundidad	Pa	Depresión salida de humos		Volumen calefactable		Profundidad cámara de combustión		Longitud leños
									Rendimiento



Chimeneas y Biomasa FERLUX, S.A.
Parque Empresarial El Pólear, Parc. 1
29313 Villanueva del Trabuco
MÁLAGA (España)
Tel. +34 952 03 11 17

FERLUX se reserva el derecho a modificar
cualquier modelo de este catálogo sin
previo aviso. Cotas a título orientativo.

ferlux.es

Distribuidor autorizado